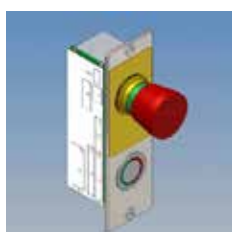

Access Control Systems

**Interlock Control System****page 08.003.00****Bar Magnets****page 08.047.00****Door Locks,
Electric Strikes,
Accessories****page 08.061.00****Access Control Systems****page 08.067.00****24 VDC, 12 VDC Power Supplies
UPS Power Supply****page 08.069.00**

State 01/2018

Interlock Control System

For the Access Control to e.g. Clean Rooms or Laboratories

In clean rooms, laboratories, hospitals etc. doors may often be opened only when others are closed. The DICTATOR interlock control system facilitates an easy configuration of these **relations**, without a complex PLC control system. The relations are "programmed" directly by DIP switches. Trained persons not requiring any special programming know-how **can modify** them **on site** at any time.

For an easy mounting the components of the newest generation are connected as telephones or networks by cables with **RJ45 connectors** (exception: ex-proof version). The power pack for the 24 VDC supply is provided with a safety plug.

The interlock doors can be unlocked either by pushing the corresponding key on the terminals or free of contact by a transponder, the transponder system having an integrated **access control**.

There are two **exceptions** from the plug-in version (here the complete electrical wiring has to be effected by the customer):

- the ex-proof version,
- the SP interlock control system for flush fitted switch boxes or pattresses.



System Versions

Peripheral system <i>beginning on page 08.011.00</i>	Extremely flexible, modular structure, can be extended at any time, complex special functions possible, also for installations with doors far apart.
Central system RJ <i>08.019.00 et sqq.</i>	For small systems with max. 5 doors (optionally 8 doors). Max. cable length 15 m. Depth of terminals only about 27 mm.
Ex-proof version <i>beginning on page 08.027.00</i>	For max. 5 doors (optionally 8 doors). Central controller SK for mounting outside the hazardous area, optionally with ex-proof casing. Also not ex-proof doors can be integrated.
Switch box version SP <i>beginning on page 08.037.00</i>	The components of the terminals are mounted in an off-the-shelf switch system. Used with central controller SK, electric connection to be provided by the customer.



DICTATOR Interlock Control System - General Information

In the DICTATOR interlock control systems all doors of the interlock system are generally locked and are released only temporarily when the operating key of the terminal is pressed. This offers the highest possible safety within the interlock system.

Every door is controlled by a separate control board. With the peripheral system these are integrated in the control terminal of the respective door, with the central controllers RJ and SK the control boards of all doors forming part of the system are united in a central controller.

Unlocking the Doors - Options

The peripheral DICTATOR interlock control system as well as the one with a central controller RJ offer **two basic options to unlock** the doors:

- Terminals with key

Here is used the **piezo-type key** with illuminated ring described in the following. Information about the keys in the ex-proof system and those for the SP switch box system can be found on the pages 08.031.00 respectively 08.040.00.)

- RFID terminals without key operated by transponders (integrated access control)

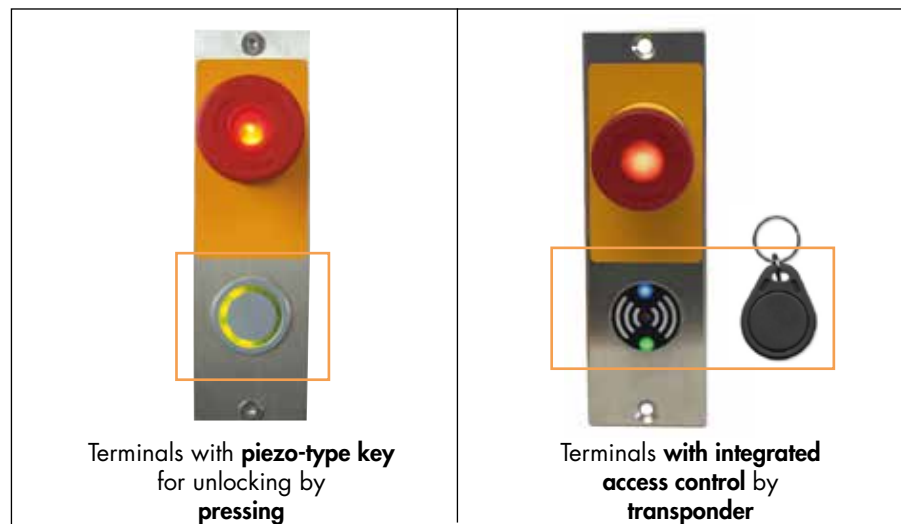

An additional possibility to unlock the door is to connect an external switch, e.g. a large surface switch.

Piezo-type key

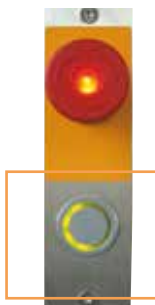

The piezo-type key is ideally suited for its use in clean rooms. It features no mechanical moving parts where dirt could settle and it is not subject to mechanical wear. It offers a very long operational life of 20 million operations. It also is very resistant to environmental influences. Its operation requires only a very slight pressure.

Indication of the door status

The illumination on the terminals clearly signals the user whether the respective door can be used or is locked at the moment. The terminals of the peripheral and the central RJ system with piezo-type key have an illuminated ring around the operating key. The ex-proof terminals have an extra illuminated green/red indicator:

Green: The door is locked, but can be opened by pressing the operating key.

Red: The door is locked. At the moment it cannot be opened. The illumination of the ring will return to green as soon as it will be possible to request the opening by pressing the key.



DICTATOR Interlock Control System - General Information, cont.

The terminals with piezo-type key and transponder of the peripheral and central RJ interlock control system can be combined at will, also on one door. Both models have the same dimensions.

This allows, if necessary, to equip certain areas of the interlock system with an **automatic access control without** needing **additional devices**. The interlock system or parts of it can only be accessed by a restricted group of people.

Transponder



DICTATOR developed terminals for the interlock control system that feature an **integrated access control**. The piezo-type key is replaced by a RFID system. This allows to change authorizations any time and also to attribute different authorizations within one interlock system.

On both sides of each door different authorisations can be programmed.

Instead of pressing the piezo-type key, the door is unlocked by a transponder. The RFID system has been designed so that it can be operated by off-the-shelf transponder chips. The optimum reading distance between terminal and transponder chip is 1 - 2 cm.

Transponder chip requirements

- Frequency: 125 kHz
- Memory: 64 Bit
- Type of chip: EM 4100, EM 4102, EM 4200

Programming

To begin with the three administration transponders are programmed: one delete transponder, admin transponder and master transponder each. As these transponders have different functions, they should have different colours (see below) to be able to distinguish them at once.

Functions of the administration transponders:

Delete transponder: It deletes all programming of a terminal and restores it to its original condition.

Admin transponder: Using this transponder you can program/delete the user transponders per terminal.

General transponder: "Master key" for all terminals on which it has been programmed. It cannot be deleted on single terminals (like the user transponders).

It is recommended to program a set of administration transponders per interlock system (not per terminal!).

After this procedure the system automatically turns into the **operation mode**. Now the user transponders can be programmed (determination of the doors which a user or a group of users may open with the transponder), **max. 99 user transponders** per terminal. By means of the admin transponder it is always possible to delete single user transponders from the access authorisation of single doors. In the event of a power cut all programmed authorizations remain stored.

Indication of the door status

The terminals of the RFID series feature beside the green and red LED also a blue LED.

Green/Red: The function of the green and red LED corresponds to the illuminated ring of the piezo-type keys (see preceding page).

Blue: The blue LED informs by different blinking sequences or the duration of the illumination about the operating state of the terminal. This way it also controls the training and programming process of the different transponders.



DICTATOR Interlock Control System - General Information, cont.

The interlock control system is a very flexible system. Without needing a time-consuming new programming, the complete interlock control system can easily be adapted to changing requirements.

"Programming"



One of the **main features** of the DICTATOR interlock control system is the **very easy "programming"** of the relations between the doors. No computing skills at all are needed.

All relations are adjusted by DIP switches.

The **peripheral version** features these DIP switches **directly in the control terminals**. In the **central systems** they are placed **on the circuit boards in the central controller**.

The relations between the doors can be adapted any time. It is also easily possible to later enlarge the interlock control system.

More detailed information and a programming example can be found on page 08.009.00.

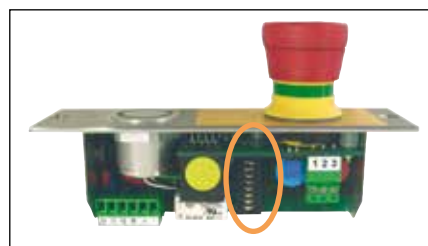

On the same circuit board (either in the control terminal or in the central controller RJ) you can adjust by means of a potentiometer the time during which the door will remain unlocked, i.e. the door can be opened after the operating key has been pressed or the transponder has been held in front of it. It is of no importance whether the door is really opened or not. The period to be adjusted depends on whether it is an interlock for people or material.



Emergency-Open Switch

The door terminals of the peripheral and the central interlock control system are available either with just an operating key or with an additional **emergency-open switch**.

In case of an emergency the door can be unlocked by pressing the emergency-open switch even while being locked by the interlock control system. The switch remains locked after having been pressed. In order to reactivate the interlock control system the emergency-open switch has to be unlocked by turning. After a short delay the system is ready to work again.

If necessary, the emergency-open switch can be protected by an extra cover against unauthorised use (cover prepared for a lead seal, see page 08.045.00).

Two different emergency-open functions are possible:

- **Local emergency-open (LNA)**: unlocks only the door of the respective terminal.
- **Global emergency-open (GNA)**: unlocks all doors of the group.



DICTATOR Interlock Control System - General Information, cont.

The DICTATOR interlock control system is a modular system which can also integrate non-system components. Depending on the chosen version it also offers a great variety of additional possibilities.

Some of the options mentioned in the following are not possible in the ex-proof version of the system or the system for switch range SP. Details about these two versions and the possible options can be found beginning on page 08.027.00 respectively 08.037.00.

Locking Devices

To lock interlock doors bar magnets, electric strikes etc. can be used. A big choice can be found in the catalogue beginning on page 08.047.00.

But also already installed locking devices can be included in the DICTATOR interlock control system. For this purpose they have to meet the following requirements:

- they have a feedback contact which is closed when the door is closed (if necessary, it can be mounted separately),
- they function with 24 VDC and
- they are locked with current.

Access Controls

Also **external access controls** can be connected to all terminals of the interlock control system (only exception are the ex-proof ones). There are two options for their functioning:

- entering the access code automatically releases the door.
- in addition to entering the access code the piezo-type key of the terminal has to be pressed.

Information about an access control system can be found beginning on page 08.067.00.

Access control systems that are already installed, have to have a potential-free make contact (NO) (switching time about 1 sec.).

If possible, the access control system should function with 24 VDC as it then can be fed by the power pack of the interlock control system.

Additional Switches (e.g. Large Surface Switches)

The DICTATOR interlock control system allows also to connect large surface switches or something similar to adapt the interlock control system optimally to the needs of the users. Large surface switches are very convenient when the persons passing through the interlock door have to carry something and therefore don't have empty hands or when they are handicapped.

Integration of Emergency Exits

Interlock control systems often also include emergency exits. These have to be equipped according to the requirements of the EIVTR (German standard for electrical locking systems on emergency exits).

For this purpose DICTATOR has developed as a special component the emergency exit terminal which has been tested and approved by the TÜV Thüringen. This terminal can easily be integrated in a DICTATOR interlock control system.

Door Operators

Especially in clean rooms interlock control systems form part of a production process. There doors often should open automatically. The DICTATOR interlock control system also easily allows to integrate door operators in the interlock system. The door operator should have the following characteristics:

- automatic closing. If not, a separate control device for a closing command is required.
- signal output "door closed" (NO). (If not available, a separate feedback contact has to be mounted.)

Time Control

Depending on the type of the DICTATOR interlock control system there are different possibilities to reopen certain doors of the interlock system only after an adjustable period. This can be achieved in a restricted way by the "Plus" terminals. For more comfortable functions a separate time module is available.



DICTATOR Interlock Control System - General Information, cont.

Depending on the type (peripheral, central, ex-proof) the system can be combined to different extents with facility management systems and a large number of additional functions can be achieved.

The standard version of the DICTATOR interlock control system (peripheral or central RJ) is very easy to mount and connect. No specialist is needed. All intrasystem components are connected by flat cables with RJ45 connectors. Also the power pack is ready for plug-in in a 230 VAC socket.

Discretion Circuit

The interlock control system allows to establish a discretion/delaying circuit for any doors. These doors cannot be opened from the outside even when all other doors are closed, as long as they are locked from the inside by a separate switch to be provided on site (e.g. for undisturbed changing).

Relay Controlled Additional Functions

The control terminals of the peripheral system and the control boards of the central system dispose of different signal outputs/status indications.

They all can be used for transmission to a facility management system.

The peripheral interlock control system allows also for many relay based additional functions. Among these are:

- Starting a ventilation/heating.
- Switching on/off lighting.
- Controlling a pressure compensation.
- Optical/acoustic warning signals.

Number of Doors in Interlock Systems

The DICTATOR interlock control system is also very suitable for smaller interlock systems. Due to its very easy mounting, wiring and "programming" the DICTATOR interlock control system represents an ideal solution to the always increasing requirements regarding hygiene and clean rooms.

The number of doors in the interlock control system depends on the type of the interlock control system.

Peripheral interlock control system

The standard version of the peripheral system has been designed for up to 8 doors. But it also can be used for more doors if the doors can be combined to several groups. At a maximum there can be controlled 8 groups of doors with 8 doors each.

Interlock control system with central controllers RJ and SK

The version with the central controller has been designed for installations with up to 5 doors. But also the central system is very flexible and can be extended to up to 8 doors. But this system requires that all connected doors have to be within the reach of a max. 15 m long cable to the central controller.

Ex-proof interlock control system

The ex-proof system with the central controller SK can also control up to 5 doors. Also this system can be extended to a maximum of 8 doors. But here the ex-requirements have to be observed.

SP interlock control system for flush fitted switch boxes or pattresses

The interlock control system for the switch system Jung LS 990 uses the central controller SK which has to be wired on site. The maximum number of doors corresponds to the one of the central system.

We would be happy to work out a free of charge offer with a solution proposal. Just ask us.



Interlock Control System - Programming

The following matrix helps you to determine the position of the DIP switches on the control boards. Just mark for each door which other door(s) may be open at the same time and which one(s) must stay locked (see example below).

There are 3 positions for the DIP switches:

Position +: defines the door for which the relations are set (basis door)

Position -: this door is locked as long as the "basis door" is open.

Position 0: this door can be opened even though the "basis door" is open, too.

Clean room interlock system with 5 doors

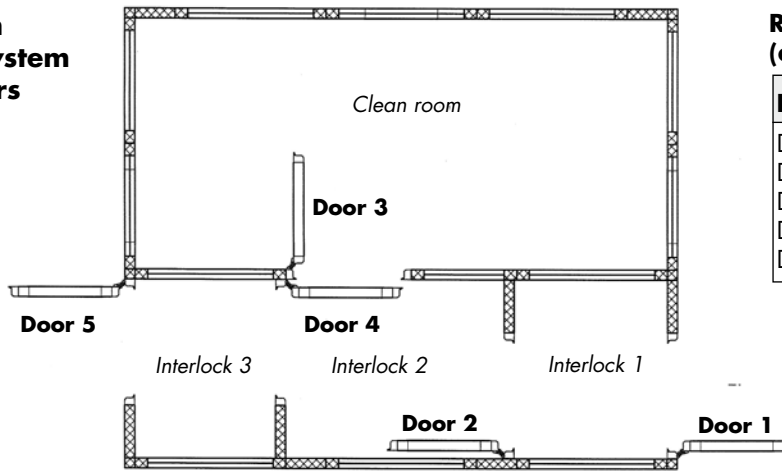

Required relations (determined by the customer)

Door open	Door locked
Door 1	Door 2
Door 2	Doors 1, 3 and 4
Door 3	Doors 2 and 4
Door 4	Doors 2, 3 and 5
Door 5	Door 4

Matrix for setting the positions of the DIP switches

Door number No. of the basis door	Admissible state of the other doors of the interlock system depending on the open "basis door"							
	1	2	3	4	5	6	7	8
1	+	-	0	0	0	0	0	0
2	-	+	-	-	0	0	0	0
3	0	-	+	-	0	0	0	0
4	0	-	-	+	-	0	0	0
5	0	0	0	-	+	0	0	0
6								
7								
8								



DICTATOR Interlock Control System - Summary

On the following pages you will find detailed information about the different types of the DICTATOR interlock control system and the components which can be used for upgrading the peripheral as well as the central version.



Peripheral interlock control system

Overview	page 08.011.00
Components	page 08.012.00
Control terminals ST3	page 08.013.00
Operating terminals BT3	page 08.014.00
Distribution box	page 08.015.00
Connection cables	page 08.017.00
Order information	page 08.018.00



Central interlock control system

Overview	page 08.019.00
Components	page 08.020.00
Central controller RJ	page 08.021.00
Operating terminals BTZ	page 08.023.00
Operating terminals BT3	page 08.024.00
Connection cables	page 08.025.00
Order information	page 08.026.00



Ex-proof interlock control system

Overview	page 08.027.00
Components	page 08.028.00
SK central controller	page 08.029.00
Operating terminals BTZ EX	page 08.031.00
Ex-proof locking magnet	page 08.032.00
Order information	page 08.036.00



SP interlock control system for flush fitted switch boxes or pattresses

Overview	page 08.037.00
Components	page 08.038.00
SK central controller	page 08.039.00
Operating terminals for switch range	page 08.040.00
Order information	page 08.041.00



Additional components for the peripheral and the central type

Emergency exit terminal	page 08.043.00
Time control unit	page 08.044.00
Mounting accessories	page 08.045.00
Order information	page 08.046.00



Peripheral Interlock Control System - Overview

The peripheral DICTATOR interlock control system is the most flexible type of the interlock control systems. Its modular structure offers the possibility to meet an extraordinary number of special requirements.

All intrasystem components are connected by pluggable cables. Except for the alimentation these are flat cables with RJ45 connectors.

The peripheral interlock control system has been designed for up to 8 doors respectively 8 groups of doors of **maximum 8 doors each**.

Basic Set-up

The basic set-up of the peripheral DICTATOR interlock control system is very simple:

The doors of the interlock system are directly controlled by the control terminals on the doors. The distribution boxes work as junctions between the control terminals. Depending on the number of doors in the interlock system and their spatial arrangement, 1 to max. 4 doors can be connected to a distribution box (see also page 08.015.00). The distribution boxes are connected by pluggable cables, one for the power supply and one as control cable.

The distribution box is connected to each of its respective doors by a pluggable control cable and a power cable.

Every door needs a control terminal. In case the door shall be controlled from both sides, an operating terminal has to be mounted on the other side of the door. As this is controlled by the control terminal, it does not need an elaborate circuit board.

The locking element of the door (bar magnet, electric strike etc.) is connected directly to the control terminal.

All control cables, also the one to the locking element, are simple flat cables with RJ45 connectors. If necessary, it is possible to lengthen them by a connector to a maximum length of 15 m between two components.

The system also offers the possibility to integrate the interlock control system in a facility management system, to realize special functions, to output status information etc.

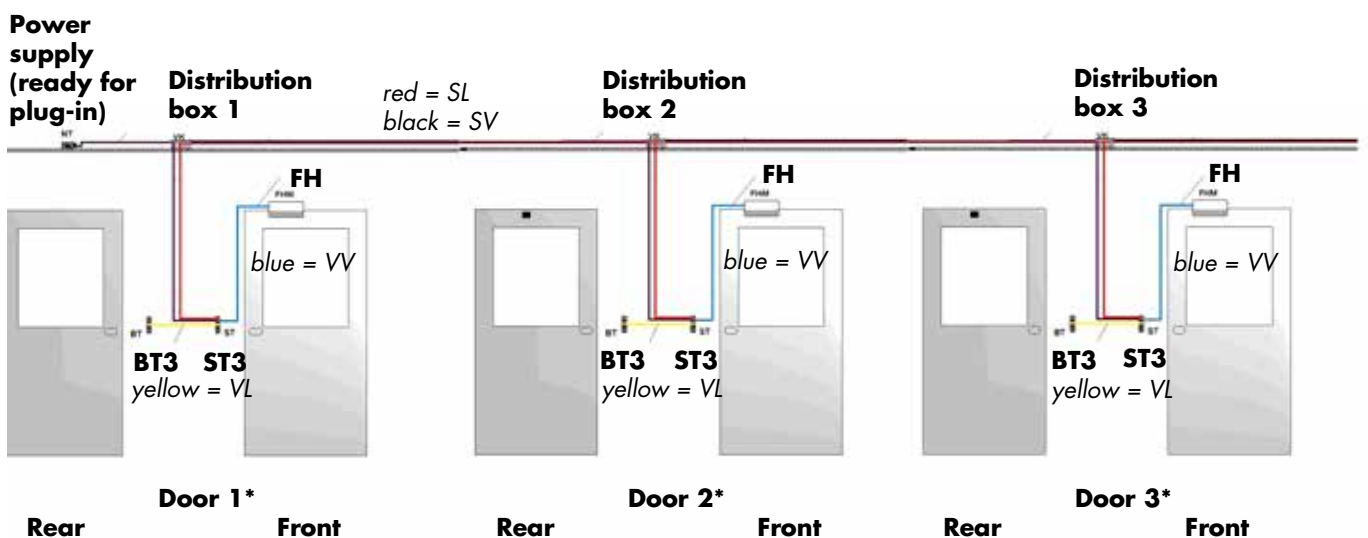

*: To each distribution box can be connected 1 to maximum 4 doors (4 doors only when in total only 1 distribution box is used, see page 08.015.00)

Legend:
ST3 = control terminal
BT3 = operating terminal
FH = bar magnet/locking device

SL = control cable (red)
SV = power cable (black)
VL = connection cable ST3-BT3 (yellow)
VV = connection cable ST3-FH (blue)



Peripheral Interlock Control System - Components

The peripheral DICTATOR interlock control system consists of a few main components. They are completed by mounting accessories and components for special functions.

The locking elements used have to meet two requirements: A feedback contact that is closed when the door is closed, and to function with 24 VDC quiescent current, i.e. with current they are locked.

System Components

Control terminal

Per door there is needed one control terminal. It is the core of the peripheral interlock control system. In the control terminal are determined the relations of this door in reference to the other doors of the interlock system by DIP switches. It can be provided either with or without an emergency-open switch.

The control terminals are available as Basic or Plus model (for additional functions). They are operated either by an piezo-type key or the RFID terminals by a transponder chip (integrated access control). Further details can be found on the next pages.

Operating terminal

Normally an additional terminal is required for the rear side of the door. This operating terminal also comprises only an operating key or the RFID system or also the emergency-open switch. The operating terminal is connected to the control terminal by a flat cable with RJ45 connector.

Connection cable

The connection cables play an essential part in making the DICTATOR interlock control system such an easy to handle system. All control cables and the connections to the locking elements are flat cables with RJ45 connectors. The cables and the corresponding sockets are clearly marked by colours to prevent any faulty connection during installation. In case of need, the cables can easily be lengthened by using simple connectors up to a maximum distance of 15 m between the single components.

For the power supply there are available, depending on the required function, 2 core or 6 core cables with connectors on both ends.

Distribution box

The distribution box has been designed for 1 up to maximum 4 doors. Both, the control cable and the power cable, are simply clipped to it. In addition it offers space for the relays needed for additional functions.

Central power pack

The 24 VDC power supply of the terminals and the locking units is provided by a central power pack. It is available either with 2.7 A or 5 A power. The power pack is furnished ready for mounting with a mains cable with safety plug and a 2 m long 24 VDC cable with 6-pin connector to one of the distribution boxes of the system, i.e. it doesn't have to be opened for connection.

Locking elements

For locking the doors there is available a large choice of bar magnets and electric strikes (see page 08.047.00 and the following). It is essential that the used locking devices dispose of a potential-free feedback contact.

Emergency exit terminal for emergency exit doors according to EltVTR

In case of emergency exits in the interlock system, it is easy to integrate them with the help of the tested emergency exit terminal.

Time control unit

If the interlock system includes doors that shall be free only after a certain time (for decontamination, reaching determined temperatures etc.) and the remaining time should be indicated to the persons in the interlock, the DICTATOR time control unit together with the corresponding secondary indication displays will accomplish this.

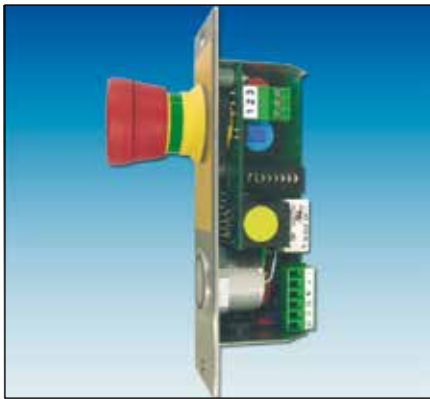

Peripheral Interlock Control System - Control Terminal

The control terminal is the **central component** of the peripheral DICTATOR interlock control system as it contains the control circuit board where the relations between the different doors are set. See the information beginning on page 08.004.00. They are operated either by a piezo-type key or the **RFID terminals** by means of a transponder which offers an **integrated access control**. The DICTATOR terminals meet the requirements of clean rooms. Both front plate and key are made of stainless steel.

The front plates of the terminals have been designed for their mounting in hollow profiles. On demand, front plates with differing measurements and with the customer's logo are available.

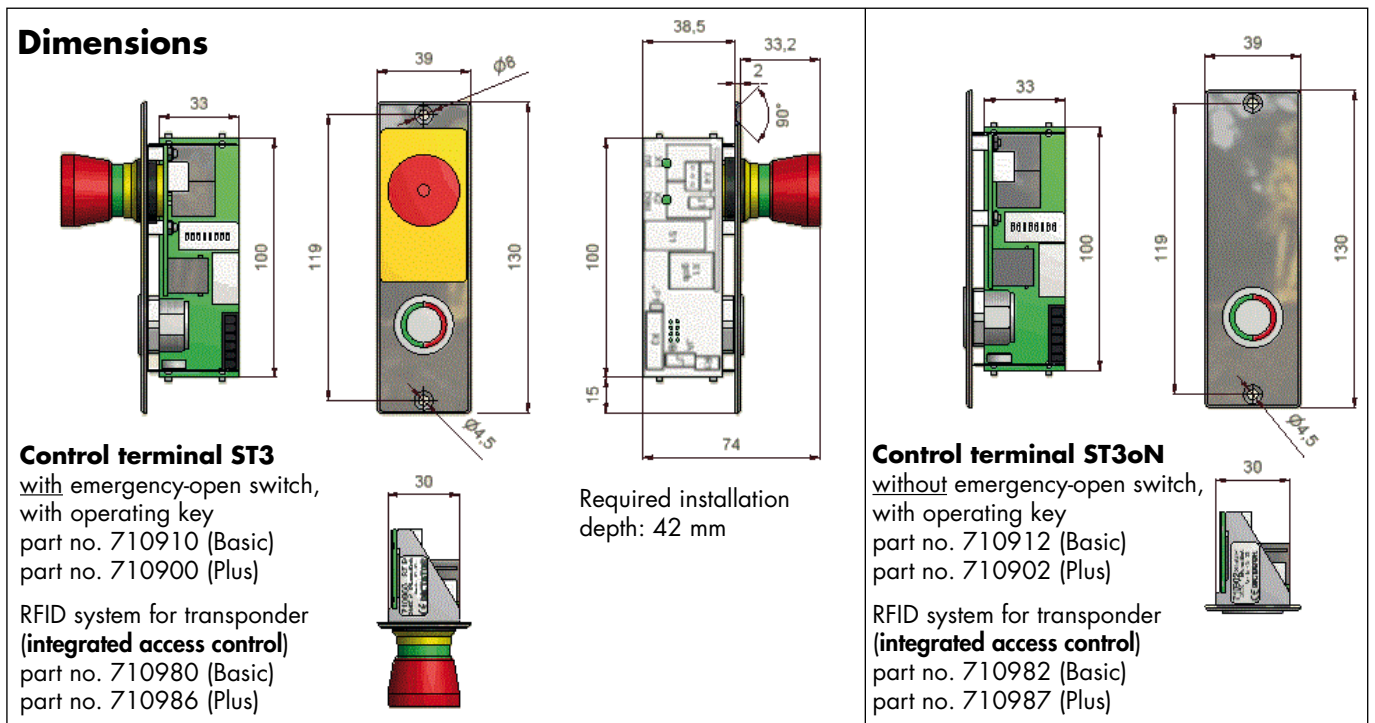

Performance

Basic version (with piezo-type key or RFID system)

- 1 signal output for actuating the emergency-open switch (if included)
- 1 signal output (to be configured by a jumper)

Plus version (with piezo-type key or RFID system)

- 1 signal output for actuating the emergency-open switch (if included)
- 2 signal outputs (to be configured by jumpers)
- Integrated time control unit without display (adjustable times: 1, 2, 3, 4, 5 minutes. On demand different times are possible ex factory.)

Technical Data

Power consumption <u>with</u> emergency-open	24 VDC +/-15 %, max. 50 mA
<u>without</u> emergency-open	24 VDC +/-15 %, max. 40 mA
IP rating	IP 20* (operating key/emergency-open: IP 65)
Capacity per output	250 mA, make contact (NO)
Operating temperature	-10 °C to +40 °C
Operation	piezo-type key with red/green circle illumination (requires only a pressure of 1.5 - 3 N!) or transponder in case of RFID terminals
Emergency-open switch	mushroom-type push-to-lock, illuminated
Emergency-open contact set (capacity)	1 make contact (NO): 500 mA
Material front plate	AISI 304

*IP rating when not built in.
The final IP rating depends on the mounting situation.



Peripheral Interlock Control System - Operating Terminal

Normally the doors of an interlock system are used from both sides. Therefore, an additional operating terminal (without control board), connected to the control terminal, is required on the rear side of the door. The operating terminal is available only as standard type (no distinction between Basic and Plus version).

Control and operating terminals with operating key or RFID system can be combined at will. The front plates of the terminals have been designed for their mounting in hollow profiles. On demand, front plates with differing measurements and with the customer's logo are available.

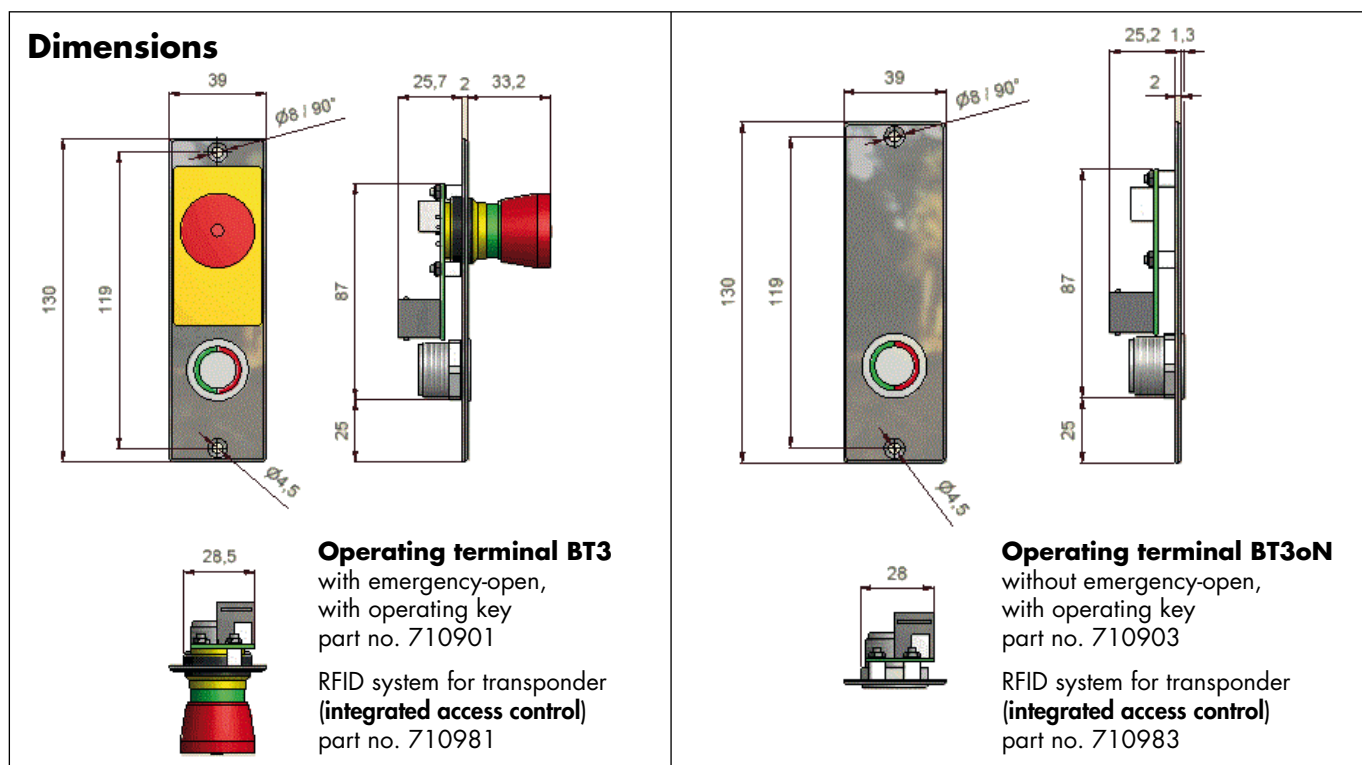

The operating terminal is connected to the control terminal by the connection cable with RJ45 connector (marked yellow). The cable has to be ordered separately. By default two lengths are available:

- 250 mm (part no. 710936)
- 1000 mm (part no. 710937).

To the operating terminal, same as to the control terminal, can directly be connected an access control (already integrated in the RFID terminals) or also a large surface switch for example.

Technical Data

Power consumption	24 VDC +/-15 %
with emergency-open	max. 30 mA
without emergency-open	max. 15 mA
IP rating	IP 20* (operating key/emergency-open: IP 65)
Operating temperature	-10 °C to +40 °C
Operation	piezo-type key with red/green circle illumination or transponder in case of RFID terminals
Emergency-open switch	mushroom-type push-to-lock, illuminated
Emergency-open contact set (capacity)	1 make contact (NO): 500 mA
Material front plate	AISI 304

*IP rating when not built in. The final IP rating depends on the mounting situation.



Peripheral Interlock Control System - Distribution Box

The simple wiring of all the components in the peripheral interlock control system is based on the distribution box(es). If there are several distribution boxes, these are connected with a pluggable control cable and power cable each. The control terminals of the corresponding doors are then connected to the distribution box by also pluggable connection cables.

Number of Required Distribution Boxes

Each distribution box disposes of 4 sockets each for the control and the power cables. These are used to connect the control terminals and, if needed, several distribution boxes.

Example 1: Interlock system with 4 adjoining doors

Here one distribution box is sufficient to connect all doors directly.

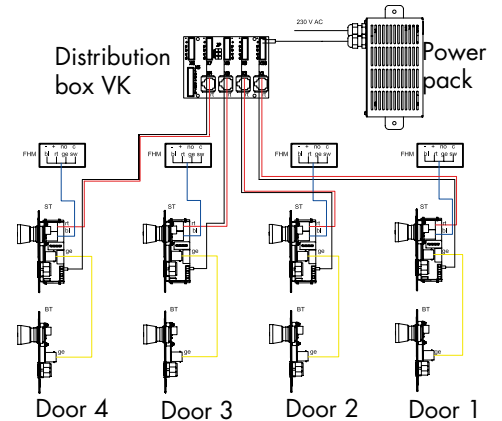

Example 2: Interlock system with 8 doors

To the distribution box 1 can be connected 3 doors. The 4th sockets are needed for the connection cables to the 2nd distribution box.

To the 2nd distribution box can be connected 2 doors as 1 socket each is needed for the incoming and one each for the outgoing cables. To the 3rd distribution box there can again be connected 3 doors as only one socket each is needed for the incoming connection cables.

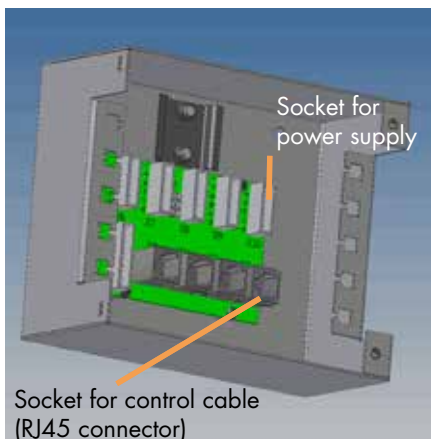
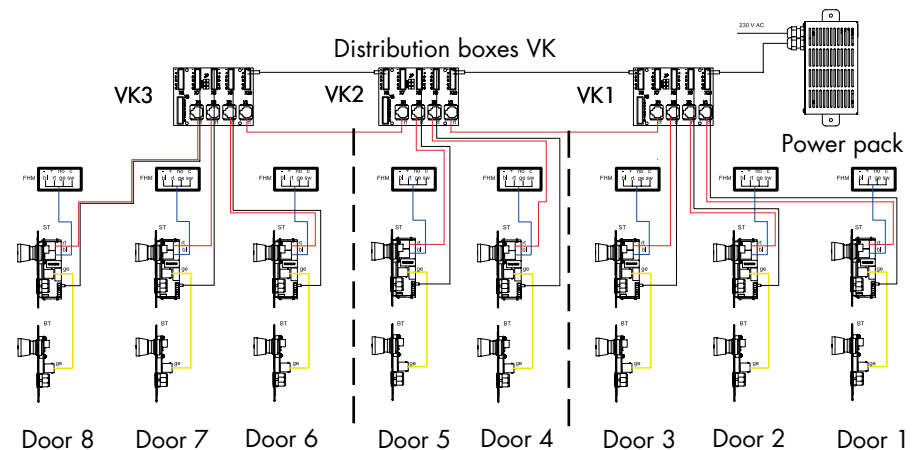

Function Global Emergency-Open

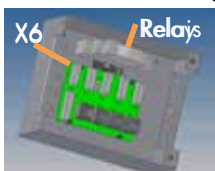

If required, the **function global emergency-open** (when pressing one emergency-open switch, all doors are unlocked) is adjusted in the distribution box. To achieve this, there is fitted an additional relay (part no. 710921) with pluggable connection cable in only one distribution box of the interlock control system. It is simply clipped to the standard top hat rail in the distribution box. For the connector of this connection cable the additional socket X6 is reserved.

ATTENTION: When choosing the global emergency-open, the 6 core power cable has to be used!

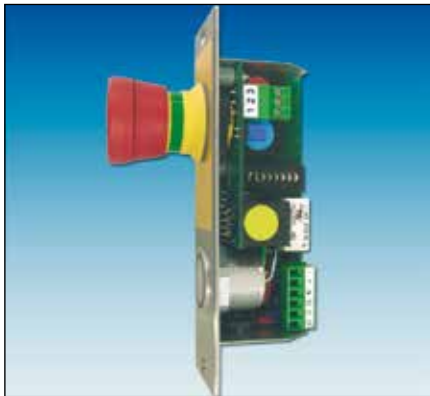

Peripheral Interlock Control System - Distribution Box, cont.

Generally the distribution boxes are fixed in the suspended ceiling or the conductor rail above the corresponding doors. But they can also be mounted at a central place if the cable length to the control terminals is not longer than 15 m.

Additional Adjustable Functions

The X5 terminal strip can be used for special functions. For example, to additionally lock any doors by a "privacy switch" (changing rooms) and to connect an external time control unit with display.

The delivery of the distribution box includes a connector for the X5 terminal strip which facilitates an easy connection of these devices.

Dimensions

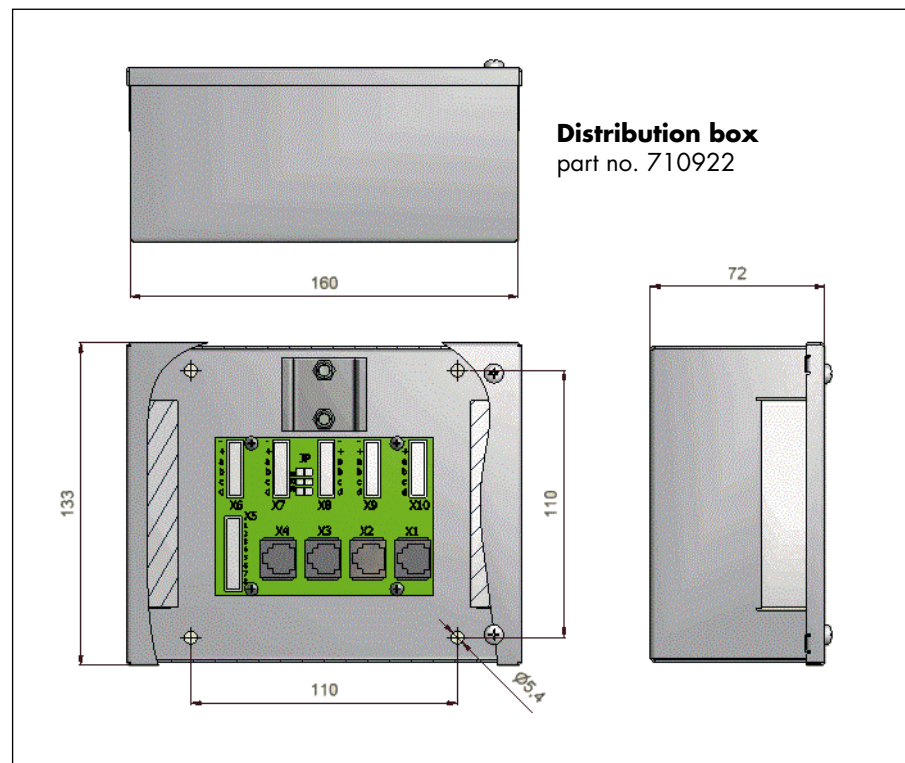

The strain relief of the incoming and outgoing cables is achieved by fixing the cables with tie wraps to the two cable support brackets. The cable inlets are sealed dust proof by cellular material.

For fixing 4 borings of $\varnothing 5.4$ mm are provided in the casing of the distribution boxes.

Technical Data

Material	hot-dip galvanised sheet steel
IP rating	IP 20
Top hat rail	type TS35/7.5 according to EN 60715



Peripheral Interlock Control System - Connection Cables

All components of the peripheral interlock control system are mainly connected by simple flat cables with colour marked RJ45 connectors. Only for the power supply are used 2 or 6 core cables with corresponding connectors, depending on the required additional functions.

This significantly reduces the mounting costs and the danger of errors when connecting the single components.

Connection Cables

Connection cable control - operating terminal (1)

The connection cable between control and operating terminal is a flat cable with **yellow** marked RJ45 connectors on both ends. It is available with a length of 250 mm and 1 m. In case the door is equipped with both, a control and an operating terminal, it always has to be ordered additionally.

But when only a control terminal is mounted on a door, there just has to be put a jumper (J1) in the corresponding place on the circuit board.



Control cable (2)

The control cable is used to connect all the distribution boxes as well as to connect the control terminals to their corresponding distribution box. The control cable is also a flat cable with RJ45 connectors. The control cable connectors and the corresponding plug-in positions are marked **red**.

Standard lengths: 3 m, 5 m and 10 m

By means of a connector (part no. 710943) several cables can be linked up to the maximum total length of 15 m between two components.

Connection of door locking device or door operator (3)

As the DICTATOR interlock control system can be combined with a multitude of locking devices the connection cable for the locking device or door operator is furnished only on one end with a RJ45 connector (**blue** colour). This is plugged in the control terminal. On the other end of the cable are 4 free leads which are marked explicitly (2 leads for the feedback contact and 2 leads for the power supply).

Standard lengths: 250 mm, 2 m, 4 m and 15 m.

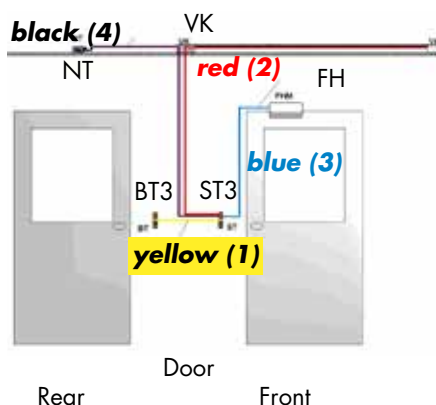

Power cable (4)

The cable for the power supply is available with 2 or 6 cores. It is used to connect the different distribution boxes as well as to connect the control terminals to the corresponding distribution box.

The 6 core cable has always to be used when a global emergency-open is required, a control terminal of the Plus version is used or special functions shall be realised.

The power cables are provided on both ends with connectors which are simply plugged in the distribution box and the control terminal. For the 2 core cables are used just the plug-in positions that are marked - and +.

Standard lengths: 3 m, 5 m, 10 m and 15 m

Connection of external components

Additional components as access controls or large surface switches have to be connected to the interlock control system by the customer. The control terminal disposes for their connection of a pluggable 3-pin screw terminal.



Peripheral Interlock Control System - Order Information

On this page you will find a summary of the part numbers of all components of the peripheral DICTATOR interlock control system.

Other accessories:

- Boxes for flush and surface mounting of the terminals page 08.045.00
- Emergency exit terminal page 08.043.00
- Time control unit page 08.044.00
- Power packs page 08.069.00 et sqq.
- Locking devices page 08.047.00 et sqq.

Order Information Terminals

(see page 08.013.00 and following)

Distribution Box

(see page 08.015.00 and following)

Time Control Unit

(see page 08.044.00)

Connection Cables

(see page 08.017.00)

Transponders for RFID Terminals

(see page 08.005.00)

Control terminal ST3 Basic		part no. 710910
Control terminal ST3oN Basic, without emergency-open		part no. 710912
Control terminal ST3 Plus		part no. 710900
Control terminal ST3oN Plus, without emergency-open		part no. 710902
Control terminal ST3T RFID Basic		part no. 710980
Control terminal ST3ToN RFID Basic, without emergency-open		part no. 710982
Control terminal ST3T RFID Plus		part no. 710986
Control terminal ST3ToN RFID Plus, without emergency-open		part no. 710987
Operating terminal BT3		part no. 710901
Operating terminal BT3oN, without emergency-open		part no. 710903
Operating terminal BT3T RFID		part no. 710981
Operating terminal BT3ToN RFID, without emergency-open		part no. 710983
Distribution box VK3		part no. 710922
Additional relay for global emergency-open, pluggable		part no. 710921
Kit of 4 pluggable 6 core screw terminals for VK3		part no. 710923
Time control unit ZS		part no. 710805
Additional display ZA for time control unit		part no. 710806
Extender circuit module for additional displays		part no. 710808
Connection cable control - operating terminal, yellow	250 mm	part no. 710936
Connection cable control - operating terminal, yellow	1 m	part no. 710937
Control cable with RJ45 connector on both ends, red	3 m	part no. 710940
Control cable with RJ45 connector on both ends, red	5 m	part no. 710941
Control cable with RJ45 connector on both ends, red	10 m	part no. 710942
Connection cable locking device/door operator, blue	250 mm	part no. 710939
Connection cable locking device/door operator, blue	2 m	part no. 710938
Connection cable locking device/door operator, blue	4 m	part no. 710928
Connection cable locking device/door operator, blue	15 m	part no. 710946
Power cable with connector, 2 cores	3 m	part no. 710930
Power cable with connector, 2 cores	5 m	part no. 710931
Power cable with connector, 2 cores	10 m	part no. 710932
Power cable with connector, 2 cores	15 m	part no. 710929
Power cable with connector, 6 cores	3 m	part no. 710933
Power cable with connector, 6 cores	5 m	part no. 710934
Power cable with connector, 6 cores	10 m	part no. 710935
Power cable with connector, 6 cores	15 m	part no. 710944
Connector for flat cable with RJ45 connector		part no. 710943
Transponder black		part no. 710850
Transponder red		part no. 710851
Transponder yellow		part no. 710852
Transponder green		part no. 710853
Kit administration transponders (one red, yellow, green each)		part no. 710854



Interlock Control System with Central Controller - Overview

The interlock control system with central controller RJ has especially been designed for installations with up to 5 doors. It can be extended to 8 doors. The central interlock control system is the ideal solution for small systems where all doors are located close to each other. The maximum cable length between terminal and central controller RJ is 15 m.

The control circuit boards being placed in the control terminals in the peripheral system, here are located in the central controller. The basic version of the central controller RJ provides control boards for 2 doors. If the interlock system consists of more doors, the controller RJ will be supplied with the corresponding number of control boards.

Basic Set-up

In the central interlock control system RJ all terminals and locking devices on the doors are directly connected to the central controller RJ.

On both sides of the doors are mounted operating terminals without controlling function. The operating terminal BTZ which is connected to the central controller RJ only has two RJ45 sockets:

Green: control cable from the central controller RJ.

Yellow: connection cable to second operating terminal (BT3) on the rear side of the door.

The second operating terminal is identical to the one of the peripheral system.

The locking device is also directly connected to the central controller RJ. The blue marked cable is plugged in the central controller RJ in the designated RJ45 socket. The other end of the cable has 4 leads of different colours to connect the locking device.

The power is provided by the power pack ready for plug-in. Its safety plug simply has to be plugged in a socket provided on site. In the central controller RJ also a socket for the power cable of the power pack is provided.

All control cables, also the cable to the locking device, are simple flat cables with RJ45 connectors. An additional power cable to the operating terminals as with the peripheral system is not required.

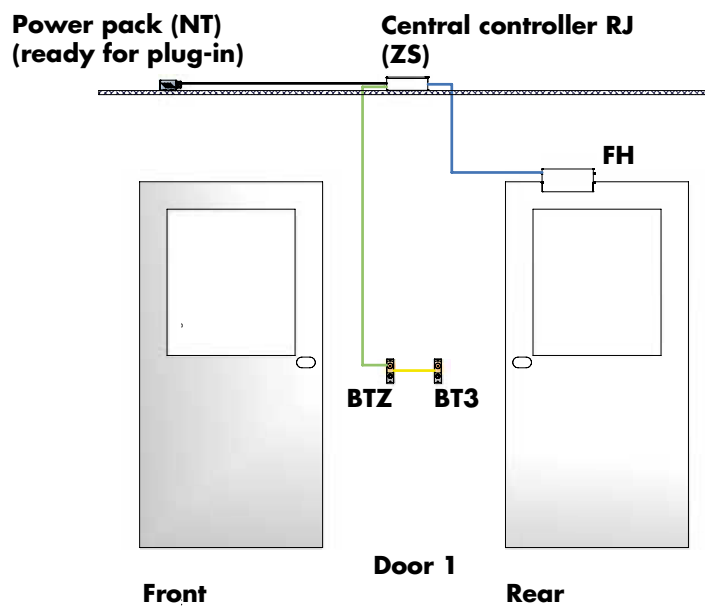

Legend:

BTZ = operating terminal with 2 RJ45 sockets

BT3 = operating terminal

FH = bar magnet/locking device

green = connection cable ZS - BTZ

black = power cable NT - ZS

yellow = connection cable BTZ - BT3

blue = connection cable ZS - FH



Central Interlock Control System - Components

The DICTATOR interlock control system with central controller consists of a few main components. They can be mounted and "programmed" with extremely little effort.

Beside the basic functions many additional requirements can be met by the central controller RJ of the DICTATOR interlock control system. For some standard components can be used, for others an additional LAN module has to be used.

Mounting accessories can be found on page 08.045.00 and the following.

System Components

Central controller RJ

Each installation requires one central controller RJ. Usually this can control up to 5 doors. But it is possible to enlarge the system. The following options are available:

- Connection of a second central controller RJ. This allows to enlarge the system to up to 8 doors (4 doors per central controller RJ).
- Connection of a distribution box of the peripheral interlock system (see page 08.015.00). This allows to control 8 doors in total: 5 doors by the central controller RJ and 3 more doors by the distribution box of the peripheral system. Each of these 3 doors needs a control terminal of the peripheral system and if necessary, an operating terminal BT3 - see page 08.013.00 and following.
- Direct connection of a control terminal of the peripheral system (see page 08.013.00), i.e. there is added 1 door to the system to make it 6 doors in total.

Operating terminal BTZ

On every door an operating terminal BTZ has to be mounted. It is available either with operating key or with RFID system for transponder chip (integrated access control).

The operating terminal BTZ provides 2 sockets for RJ45 connectors:

- green socket: connection cable to the central controller RJ,
- yellow socket: connection cable to an operating terminal BT3 on the rear side of the door.

Operating terminal BT3

The operating terminal BT3 is also used for the peripheral interlock control system. It completes the operating terminal BTZ on the rear side of the door. The only difference is that the terminal BT3 has only one (yellow) socket.

It is available either with operating key or with RFID system for transponder chip.

Connection cables

All doors are easily connected to the central controller RJ by flat cables with RJ45 connectors. The cables and their corresponding sockets are clearly marked by different colours (green, yellow, blue).

Central power pack

The 24 VDC power supply of the terminals and the locking devices is provided by a central power pack. It is available either with 2.7 A or 5 A power. The power pack is furnished ready for mounting with a mains cable with safety plug and a 2 m long 24 VDC cable with 6-pin connector to the central controller RJ of the installation, i.e. it doesn't have to be opened for connection.

Locking devices

For locking the doors is available a large choice of bar magnets and electric strikes (see page 08.047.00 and the following). It is essential that the used locking devices dispose of a potential-free feedback contact.

Additional components

- Emergency exit terminal according to EltVTR (see page 08.043.00)
- Time control unit (see page 08.044.00)



Central Interlock Control System - Central Controller RJ

The central controller RJ is the core of the central interlock control system. All control boards are placed in the central controller RJ contrary to the peripheral system where they are located in the respective control terminals. The standard version provides 2 control boards for 2 doors. In case the interlock control system consists of more doors, the central controller RJ will contain the necessary number of control boards.

The main advantage of the central interlock control system is it requires even less connection cables to the doors and all relations can be adjusted in the central controller RJ.

Structure

The central interlock control system has been designed for systems with up to 5 doors. If necessary, it can be used for up to 8 doors.

The central controller RJ consists of a basic circuit board on which are plugged the control boards of the different doors. Above each control board are 2 sockets:

- green socket for green connection cable to the operating terminal BTZ on the door.
- blue socket for the connection cable to the locking device of this door.

The power cable of the power pack is plugged in the 2-pin socket down in the right corner.

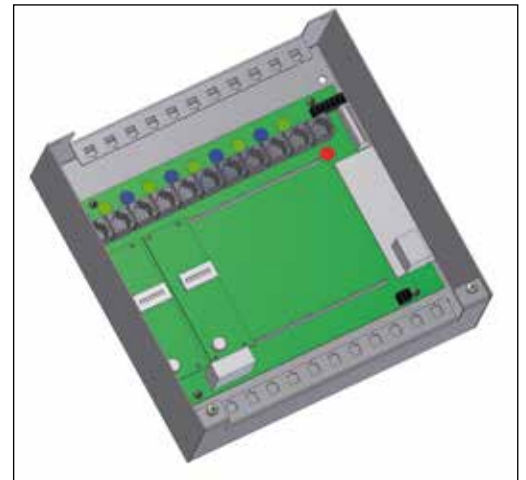

Options

Beside the basic functions several additional options can be achieved. The most important ones are listed below, with the necessary accessories.

- **Global emergency-open GNA**

In case all doors of the interlock system should open once the emergency-open switch on one of the operating terminals has been pressed (global emergency-open), this can easily be achieved - also later - by adding a relay (part no. 710953) to the central controller RJ. This relay is simply plugged in the provided socket.

- **LAN module**

It is possible to transmit status information and errors from the central controller RJ to a facility management system. For this purpose the central controller RJ can be upgraded in production with an additional circuit board (part no. 710954). This allows the facility management system e.g. to trigger an alarm, to pass an information to the ventilation system etc.

The LAN module is not included in the standard version!

- **Achieving special functions as e.g. the discretion circuit**

For this purpose an 8-pin screw-type terminal is provided in the central controller RJ.

- **Time-delayed opening**

In case it should be possible to reopen some doors only with a time delay, this can be adjusted by a jumper on the respective control board.

- **Integration of door operators**

It is also possible to integrate door operators on (some) doors of the interlock system. In this case the terminals on the respective doors have to be without emergency-open and for the operator a separate emergency-open switch has to be mounted.



Central Interlock Control System - Central Controller RJ - continuation

For systems with up to 8 doors the central controller RJ can be upgraded in several ways:

- Connection of another central controller RJ: max. 8 doors.
- Connection of a distribution box of the peripheral system. This also allows to control 8 doors in total.
- Direct connection of a control terminal of the peripheral system. This enlarges the system by 1 door to a total of 6 doors.

Dimensions

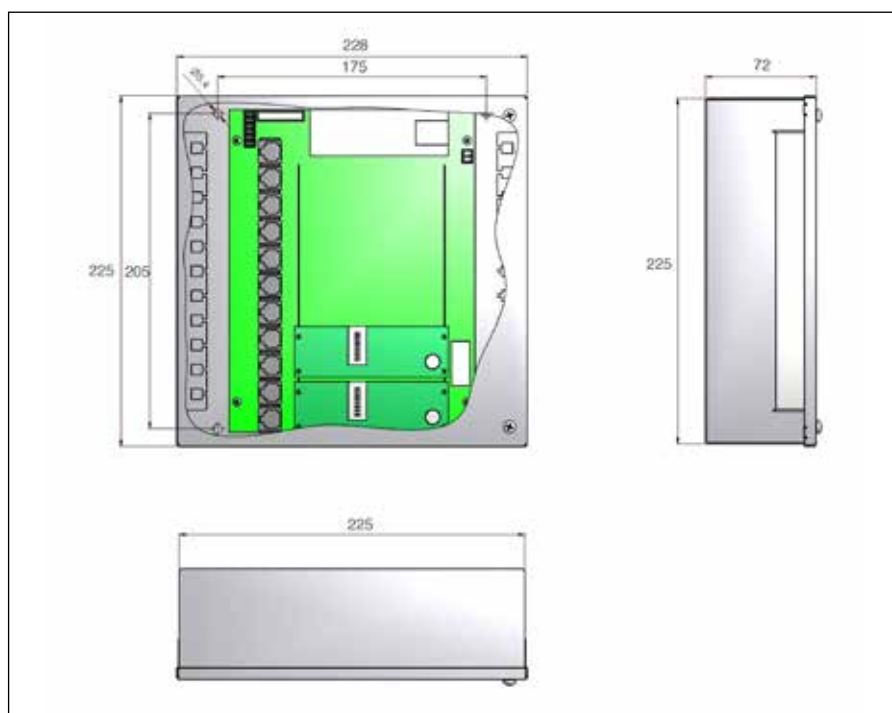

The strain relief of the incoming and outgoing cables is achieved by fixing the cables with tie wraps to the two cable support brackets. The cable inlets are sealed dust proof by cellular material.

For fixing 4 borings of $\varnothing 5.4$ mm are provided in the casing of the central controller RJ.

Technical Data

Voltage	24 VDC +/-15 %
Power consumption basic version 2 doors	100 mA
Power consumption per additional door	50 mA
Power consumption relay for global emergency-open	30 mA
Power consumption LAN module	100 mA
IP rating	IP 20
Operating temperature	-10 °C up to +40 °C
Material casing	hot-dip galvanized sheet steel
Max. cable length to terminals/locking devices	15 m



Central Interlock Control System - Operating Terminal BTZ

For the DICTATOR central interlock control system only simple operating terminals are mounted on the doors.

The operating terminal BTZ is connected by a flat cable with RJ45 connectors (green) directly to the central controller RJ. Usually on the rear side of the door an operating terminal BT3 (also used for the peripheral system) is connected to the operating terminal BTZ. The only difference between the two terminals is, that the BTZ has two sockets for flat cable (one for the cable from the central controller RJ and one for the cable to the operating terminal BT3).

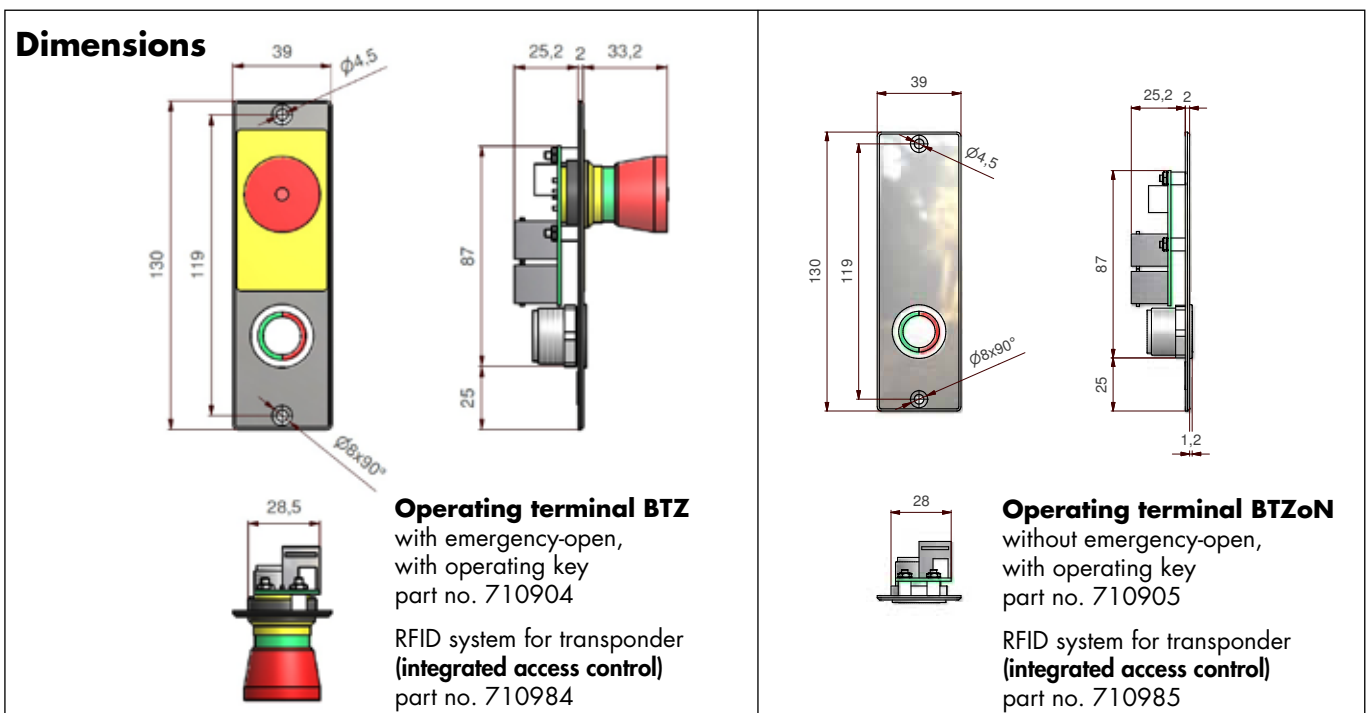

The DICTATOR terminals meet the requirements of clean rooms. The operating terminal BTZ is available with and without emergency-open switch.

For unlocking the operating terminal it is furnished either with a piezo-type key (stainless steel) or with the RFID system for transponder (integrated access control).

The operating terminal BTZ can directly be connected to an external access control (integrated in the terminal with RFID system) or a large surface switch, for example.

The flat cable (green) for the connection to the central controller RJ is available in 4 different lengths: 3, 5, 10, 15 m (for part numbers see page 08.026.00).

Technical Data

Power consumption	24 VDC +/-15 %
with emergency-open	max. 30 mA
without emergency-open	max. 15 mA
IP rating	IP 20* (operating key/emergency-open: IP 65)
Operating temperature	-10 °C to +40 °C
Operation	piezo-type key with red/green circle illumination or transponder in case of RFID system
Emergency-open switch	mushroom-type push-to-lock, illuminated
Emergency-open contact set (capacity)	1 make contact (NO): 500 mA
Material front plate	AISI 304

*IP rating when not built in. The final IP rating depends on the mounting situation.



Central Interlock Control System - Operating Terminal BT3

Normally the doors of an interlock system are used from both sides. Therefore, the additional operating terminal BT3, connected to the operating terminal BTZ, is required on the other side of the door.

The operating terminal BT3 is available with and without emergency-open switch.

The front plates of all terminals have been designed for their mounting in hollow profiles. On demand, there are available front plates with differing measurements and with the customer's logo.

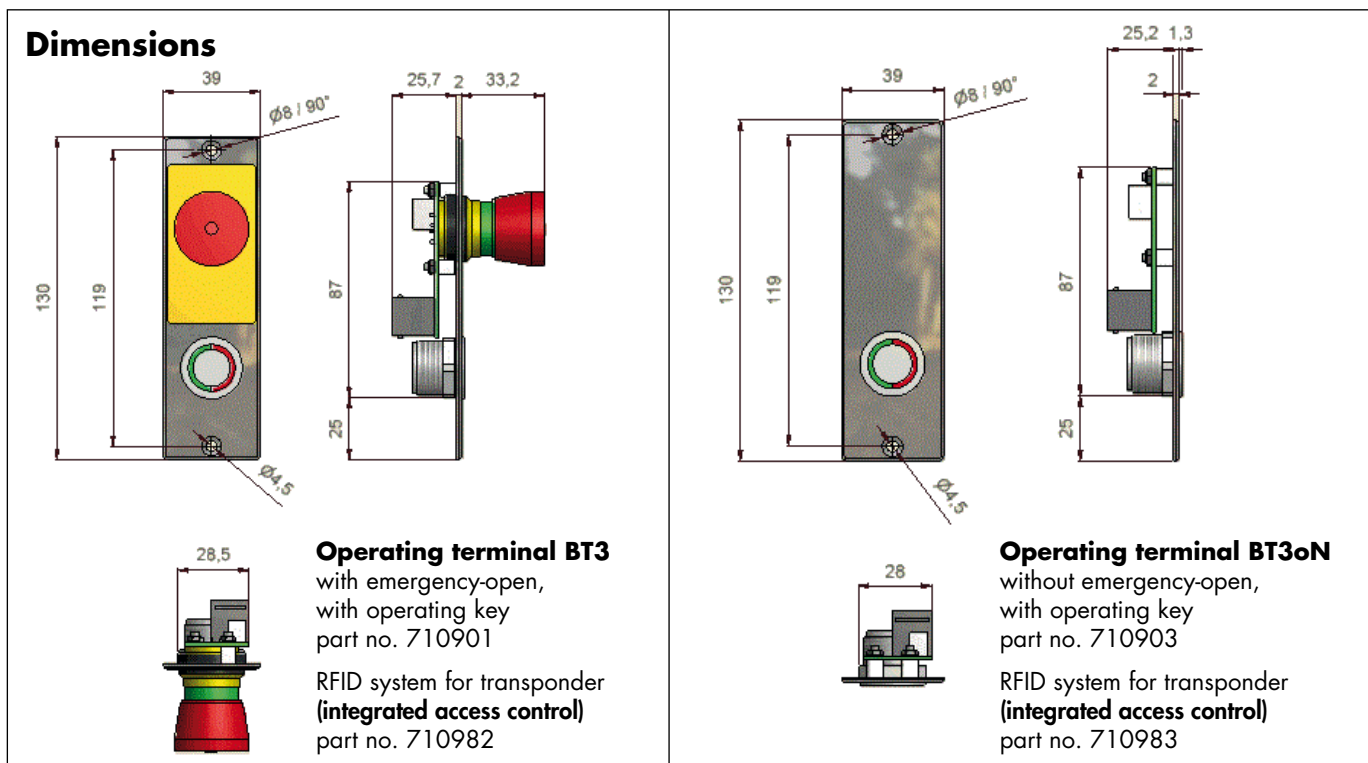

The operating terminal BT3 is connected to the operating terminal BTZ by the connection cable with RJ45 connector (marked yellow). The cable has to be ordered separately. By default two lengths are available:

- 250 mm (part no. 710936)
- 1000 mm (part no. 710937).

The operating terminal BT3 can directly be connected to an external access control (integrated in the terminal with RFID system) or e.g. a large surface switch.

Technical Data

Power consumption	24 VDC +/-15 %
with emergency-open	max. 30 mA
without emergency-open	max. 15 mA
IP rating	IP 20* (operating key/emergency-open: IP 65)
Operating temperature	-10 °C to +40 °C
Operation	piezo-type key with red/green circle illumination or transponder in case of RFID system
Emergency-open switch	mushroom-type push-to-lock, illuminated
Emergency-open contact set (capacity)	1 make contact (NO): 500 mA
Material front plate	AISI 304

*IP rating when not built in. The final IP rating depends on the mounting situation.



Central Interlock Control System - Connection Cables

The components of the central interlock control system are connected by simple flat cables with colour marked RJ45 connectors.

This significantly reduces the mounting costs and the danger of errors when connecting the single components.

Connection Cables

Connection cable central controller RJ - operating terminal BTZ (1)

The connection cable between central controller RJ and the operating terminals BTZ on the respective doors is a flat cable with RJ45 connectors on both ends. The connectors as well as the corresponding sockets are marked **green**.

Standard lengths: 3 m, 5 m, 10 m and 15 m

Connection cable operating terminals BTZ - BT3 (2)

The connection cable between the operating terminals BTZ and BT3 is also a flat cable with RJ45 connectors on both ends. The connectors as well as the corresponding sockets are marked **yellow**.

Available lengths: 250 mm and 1 m

Connection cable for door locking device or door operator (3)

As the DICTATOR interlock control system can be combined with a multitude of locking devices the connection cable for the locking device or door operator is furnished only on one end with a RJ45 connector (**blue** colour). This is plugged in the central controller RJ. On the other end of the cable are 4 free leads which are marked explicitly (2 leads for the feedback contact and 2 leads for the power supply).

Standard lengths: 250 mm, 2 m, 4 m and 15 m

Power cable (4)

The standard version of the central interlock control system RJ does not require power cables to the door terminals. The power pack is provided with a 2 m long, pluggable power cable which has just to be plugged in the corresponding socket of the central controller.

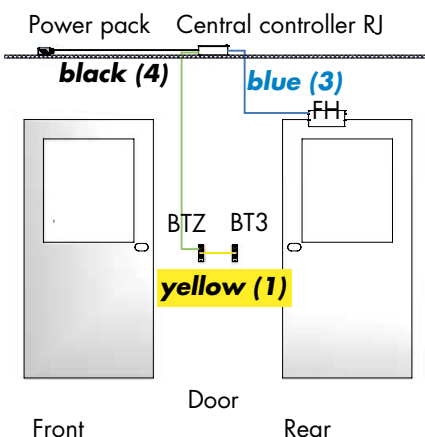

Connecting a second central controller RJ

If a central system is upgraded by a second central controller RJ, two cables are needed to connect the two central controllers RJ:

- control cable red
- 6 core power cable

Details about these two types of cables are to be found on page 08.017.00.

Connecting a distribution box VK3 of the peripheral system

For controlling 8 doors also two cables are needed to connect the distribution box:

- control cable red
- 6 core power cable

Details about these two types of cables are to be found on page 08.017.00.

Connecting external components

Additional components as access controls or large surface switches have to be connected to the interlock control system by the customer. The operating terminals BTZ and BT3 dispose for their connection of a pluggable 3-pin screw terminal.



Central Interlock Control System - Order Information

On this page you will find a summary of the part numbers of all components of the DICTATOR central interlock control system.

Other accessories:

- Flush and surface mounting boxes for the terminals page 08.045.00
- Emergency exit terminal page 08.043.00
- Time control unit page 08.044.00
- Power packs page 08.069.00 et sqq.
- Locking devices page 08.047.00 et sqq.

Order Information Terminals

(see page 08.023.00 and following)

Operating terminal BTZ		part no. 710904
Operating terminal BTZoN, without emergency-open		part no. 710905
Operating terminal BTZT RFID		part no. 710984
Operating terminal BTZToN RFID, without emergency-open		part no. 710985
Operating terminal BT3		part no. 710901
Operating terminal BT3oN, without emergency-open		part no. 710903
Operating terminal BT3T RFID		part no. 710981
Operating terminal BT3ToN RFID, without emergency-open		part no. 710983
Central controller RJ basic version for 2 doors		part no. 710920
Central controller RJ for 3 doors		part no. 710920-3
Central controller RJ for 4 doors		part no. 710920-4
Central controller RJ for 5 doors		part no. 710920-5
Additional relay for global emergency-open, retrofittable, for central controller RJ		part no. 710953
Additional circuit board (LAN module) for connection to facility management system, to be retrofitted in production		part no. 710954
Connection cable operating terminals BTZ - BT3, yellow	250 mm	part no. 710936
Connection cable operating terminals BTZ -BT3, yellow	1 m	part no. 710937
Connection cable central controller RJ - BTZ, green	3 m	part no. 710947
Connection cable central controller RJ - BTZ, green	5 m	part no. 710948
Connection cable central controller RJ - BTZ, green	10 m	part no. 710949
Connection cable central controller RJ - BTZ, green	15 m	part no. 710952
Connection cable locking/door operator, blue	250 mm	part no. 710939
Connection cable locking/door operator, blue	2 m	part no. 710938
Connection cable locking/door operator, blue	4 m	part no. 710928
Connection cable locking/door operator, blue	15 m	part no. 710946
Connector for flat cable with RJ45 connector		part no. 710943
Transponder black		part no. 710850
Transponder red		part no. 710851
Transponder yellow		part no. 710852
Transponder green		part no. 710853
Kit of administration transponders (one red, yellow, green each		part no. 710854

Central Controller RJ

(see page 08.021.00 and following)

Connection Cables

(see page 08.025.00)

Transponders for RFID Terminals

(see page 08.005.00)



Ex-Proof Interlock Control System - Overview

The interlock control system for hazardous areas functions similar to the system with central controller. The control boards of all doors belonging to the interlock system are united in a casing. Whenever it is possible the central controller should be mounted outside the hazardous area. However, it also can be placed, together with the power pack, in an ex-proof casing and then be mounted within the hazardous area.

The ex-proof interlock control system allows to control a maximum of 5 doors in the hazardous area. But it is possible to extend the ex-proof interlock control system to up to 8 doors.

Basic Set-up

In the ex-proof interlock control system all feeding lines from the terminals and locking devices of the doors are directly led to the EX central controller and connected there. In hazardous areas flat cables and RJ45 connectors cannot be used.

On the doors is mounted the ex-proof operating terminal BTZ EX. Contrary to most ex-proof operating devices it is as small and aesthetically attractive as the terminals of the other DICTATOR interlock control system types. There are available two versions of the terminal BTZ EX. It always has an operating key to request the opening of the door and a LED light to indicate the status of the door. The light is either green or red, same as the illuminated ring of the door terminals of the other interlock control systems. On both sides of the door the same type of terminal is mounted. Both are directly connected to the EX central controller. In addition the operating terminal can also be equipped with an emergency-open switch.

As locking device is used an ex-proof DICTATOR electromagnet with separate feedback contact. Magnet and feedback contact are also directly connected to the SK central controller of the ex-proof interlock control system.

The power pack which is ready for plug-in supplies the power. Its safety plug is plugged in a socket on site. In the SK central controller is provided a socket for the power cable of the power pack.

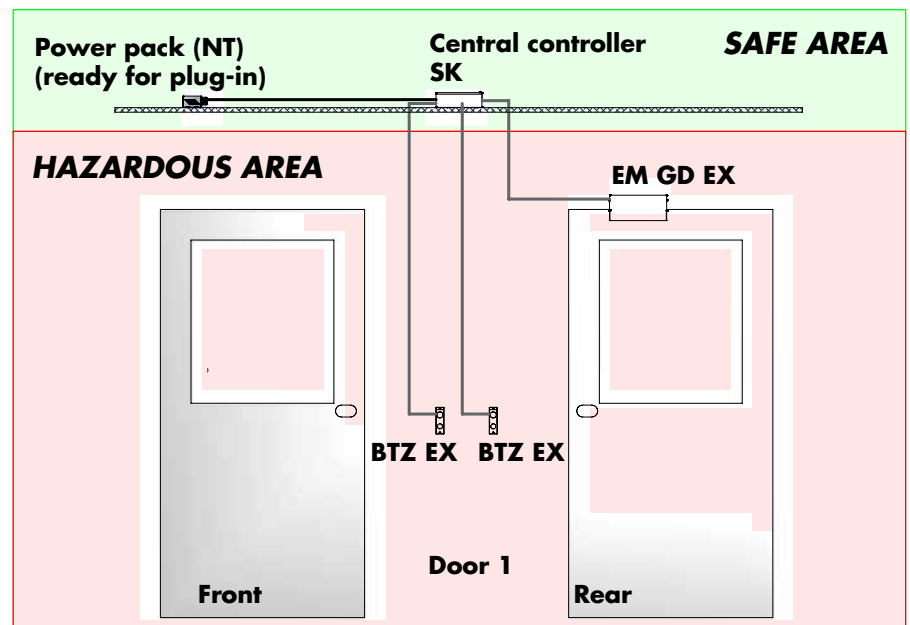

Legend:

- BTZ EX** = ex-proof operating terminal
- EM GD EX** = ex-proof electromagnet



Ex-Proof Interlock Control System - Components

The ex-proof DICTATOR interlock control system consists of a few main components. Its structure is very simple. The system is also characterised by the extremely simple programming and the attractive, small terminals.

The standard version of the SK central controller and the corresponding power pack are intended for their mounting outside the hazardous area. In case that is not possible, both components can be mounted in an ex-proof casing.

System Components

SK Central controller

There is needed one SK central controller per system. The controller itself is not ex-proof (see above). Usually it can control up to 5 doors. But it is possible to enlarge the system. The following options exist:

- Connection of a second SK central controller. This allows to control 8 doors in the hazardous area.
- Connection of a distribution box of the peripheral interlock control system (see page 08.015.00). This allows to control in total 8 doors: 5 doors from the SK central controller and from the distribution box of the peripheral system 3 more doors which need a control terminal of the peripheral system and if necessary an operating terminal BT3 - see page 08.013.00 et sq.). These 3 doors, however, have to be located outside the hazardous area.
- Direct connection of a control terminal of the peripheral system (see page 08.013.00). This adds 1 door to a total of 6 doors. But also with this version the additional door has to be located outside the hazardous area.

To the SK central controller also doors outside the hazardous area can be connected (see information on peripheral and central interlock control system). But as the cables have to be connected in the SK central controller and cannot be plugged in there is needed an adaptor for the connection of flat cables with RJ45 connector.

Operating terminal BTZ EX

On every door in the hazardous area an operating terminal BTZ EX has to be fitted. The operating terminal is provided with the corresponding connection cables to the EX central controller.

Central power pack

The 24 VDC power supply of the SK central controller is provided by a power pack. It is available either with a power of 2.7 A or 5 A. The power pack is furnished ready for mounting with a mains cable with safety plug and a 2 m long 24 VDC cable with 6-pin connector to the SK central controller, i.e. it doesn't have to be opened for connection. The power pack is not ex-proof.

Door locking device

In the hazardous area an ex-proof electromagnet is used to lock the doors. Information about the magnet can be found beginning on page 08.032.00. In addition there is required a separate ex-proof feedback contact on the doors.

Time-delayed opening

In the SK central controller it can be adjusted that certain doors of the interlock system are released only after a delay. The remaining time, however, is not indicated in the interlock.

Information about more components for doors outside the hazardous area can be found on the pages about the peripheral resp. central interlock control system.



Ex-Proof Interlock Control System - SK Central Controller

In the ex-proof interlock control system all electrically relevant parts are combined in the SK central controller. The operating terminals are connected by screw terminals as hazardous areas require special cables and the flat cables of the not ex-proof version cannot be used. Apart from that the SK central controller corresponds mostly to the central controller RJ.

The standard version contains 2 control boards for 2 doors. In case the interlock system consists of more doors, the SK central controller will be provided with the corresponding number of control boards.

Structure

The SK central controller has been designed for systems with a maximum of 5 doors. But in case of need, with a second SK central controller you can control in total 8 doors in a hazardous area.

The SK central controller contains a basic circuit board on which is attached a control board for every door. Above each control board are 3 terminal strips:

- KL 1 to connect the ex-proof electromagnet and the separate feedback contact,
- KL 6 to connect the luminous diode of the terminal,
- KL 11 to connect the Emergency-Open switch (of the operating terminal or a separate emergency-open switch)

The connection cable from the power pack is plugged in the 2 pin socket down in the right corner.

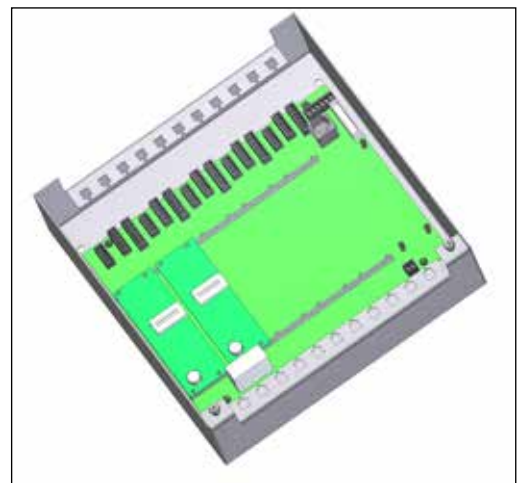

Options

Beside the basic functions a number of additional options are possible. Below are listed the most important ones with the necessary accessories.

- LAN module

It is possible to transmit status information and errors from the SK central controller to a facility management system. For this purpose the SK central controller can be upgraded in production with an additional circuit board (part no. 710954). This allows e.g. the facility management system to trigger an alarm, to pass an information to the ventilation system etc.

The LAN module is not included in the standard version!

- Achieving special functions as e.g. the discretion circuit

For this purpose an 8-pin screw-type terminal is provided in the SK central controller.

- Time-delayed opening

In case it should be possible to reopen some doors only with a time delay, this can be adjusted by a jumper on the respective control boards.

- Integration of door operators

It is also possible to integrate door operators on (some) doors of the interlock system. In this case the terminals on the respective doors have to be without emergency-open and a separate emergency-open switch has to be mounted for the operator (e.g. ex-proof push-to-lock switch, part no. 700254, page 04.067.00).



Ex-Proof Interlock Control System - SK Central Controller - continuation

- For systems with up to 8 doors the SK central controller can be upgraded in several ways:
- Connection of another SK central controller: max. 8 doors in hazardous area.
 - Connection of a central controller RJ: up to 8 doors in total, max. 5 doors in hazardous area, rest outside hazardous area.
 - Connection of a distribution box of the peripheral system: up to 8 doors in total, max. 5 doors in hazardous area.
 - Direct connection of a control terminal of the peripheral system. This way the system can be enlarged by 1 door to a total of 6 doors, max. 5 doors in hazardous area.

Components of the peripheral system can be connected by using the adaptor with the part number 710964.

Dimensions

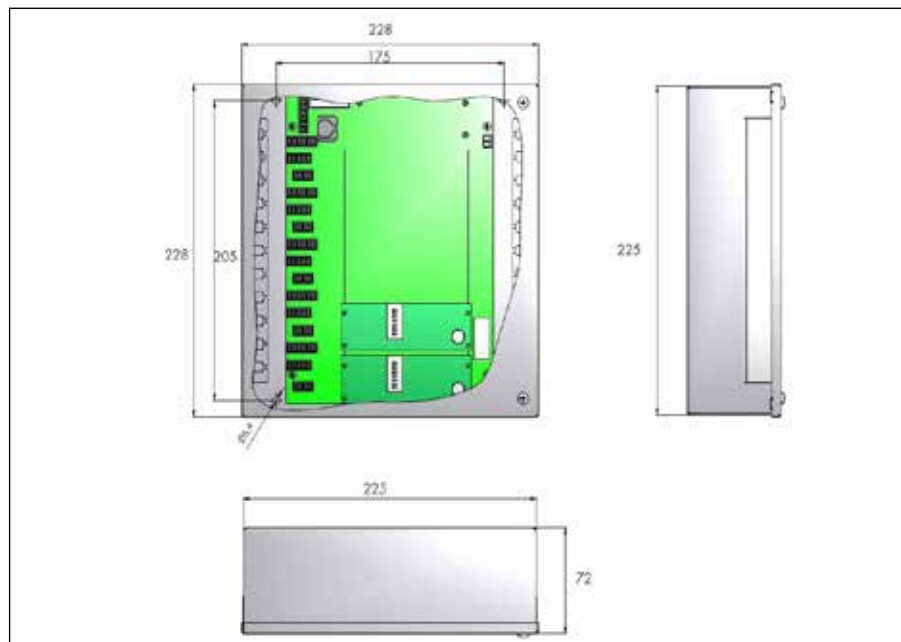

The strain relief of the incoming and outgoing cables is achieved by fixing the cables with tie wraps to the two cable support brackets. The cable inlets are sealed dust proof by cellular material.

To fix the SK central controller 4 borings of $\varnothing 5.4$ mm are provided in the casing.

If the SK central controller has to be mounted within the hazardous area, it is fitted together with the power pack into an ex-proof casing of the ex-protection type Ex II 2G Ex de IIC T6. The dimensions and the exact model depend on the number of doors the ex-proof interlock control system consists of.

Technical Data

Voltage	24 VDC +/-15 %
Power consumption basic version 2 doors	100 mA
Power consumption per additional door	50 mA
Power consumption LAN module	100 mA
IP rating	IP 20
Operating temperature	-10 °C to +40 °C
Material casing	hot-dip galvanized sheet steel
Max. cable length to terminals/locking devices	15 m
Fuse for connected EX magnets (per circuit board)	5x20 medium time lag, 200 mA
Ex-protection type of optional EX casing	Ex II 2G Ex de IIC T6



Ex-Proof Interlock Control System - Operating Terminal BTZ EX

A special feature of the ex-proof interlock control system are the operating terminals on the doors. They are as small, unobtrusive, elegant and suitable for clean rooms as the terminals of the "normal" DICTATOR interlock control systems.

With the ex-proof terminals a separate luminous display indicates the status of the door. Depending on the status it shows a green or red light.

The terminals are furnished with cables for their connection to the SK central controller. When ordering the terminals please consider the required length of cable (5, 10 or 15 m).

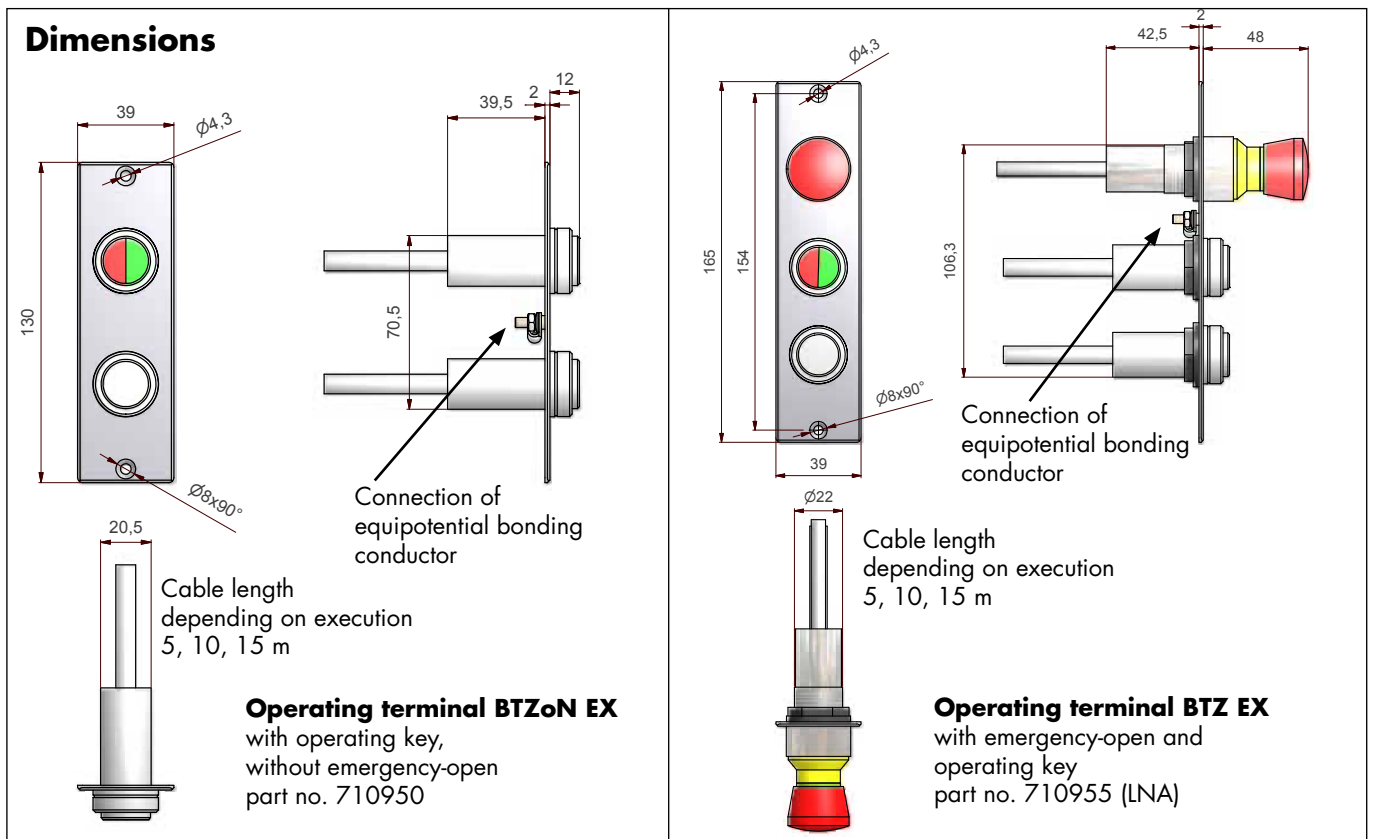

The operating terminal EX is available with and without emergency-open switch. The type with emergency-open is slightly longer. Its front plate measures 165 mm instead of the 130 mm of the type without emergency-open switch. The emergency-open switch on a terminal unlocks only the respective door (LNA).

Technical Data

Power consumption	24 VDC +/-15 %, ca. 17 mA
Ignition protection type	EEx d IIC T6/T5
IP rating	IP 68
Operating temperature	-10 °C to +40 °C
Operating key	key 22
Luminous display	LED 22, two coloured green/red
Emergency-open switch	mushroom-type push-to-lock
Emergency-open switch contact set (capacity)	1 make/break, 1.5 A at 24 VDC
Material front plate	AISI 304 stainless steel



Ex-Proof Interlock Control System - Ex-Proof Electromagnet

As locking device is mounted the tested and approved ex-proof electromagnet DICTATOR EM GD 70 with a holding force of 1450 N. If in case of special applications the holding force should not be sufficient, several electromagnets can be used.

The electromagnet comes with a cable that is connected to the SK central controller. Depending on the distance, cables of 5, 10 and 15 m length are available.

The electromagnet is registered at the PTB (German national metrology institute providing scientific and technical services) under the type-examination certificate PTB 03 ATEX 2174 X and the information of being conform with the PTB design 03 ATEX N060.

Ex-proof Electromagnet



Dimensions

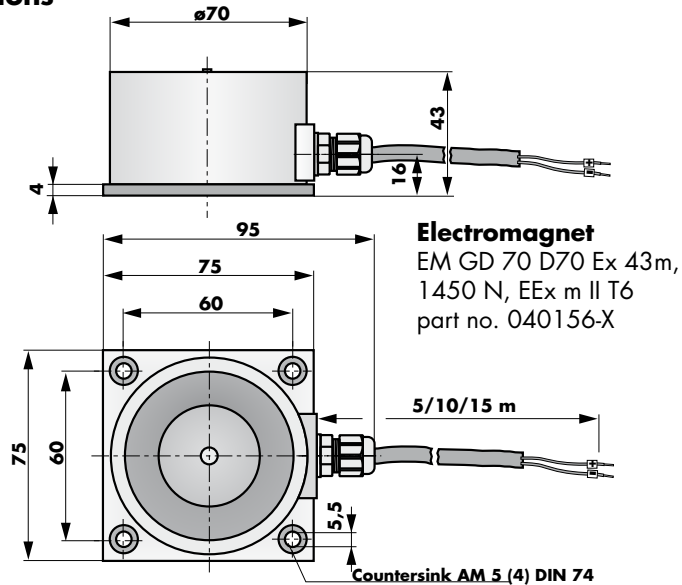

To accomplish the mounting every magnet needs a potential equalisation. On the mounting plates is provided a connection for connecting an equipotential bonding conductor (to be provided on site).

For safety reasons every magnet must have a superposed fuse, max. $3 \times I_B$ according to IEC 60127-2-1, as protection against a short circuit. One fuse per door is already included in the SK central controller.

The ex-proof electromagnet EM GD 70 does not have an integrated feedback contact. This has to be mounted separately.

Technical Data

Supply voltage	24 VDC, $\pm 15\%$
Max. permitted ripple	20 %
Power consumption ($\pm 15\%$)	70 mA (1.7 W)
Holding force / Remanence	1450 N / 0 N
Ex-protection	II 2G EEx m II T6
IP rating / Duty cycle	IP 66 / 100 %
Operating temperature	-20 to +40 °C
Finishing magnet	zinc-plated



Ex-Proof Interlock Control System - Ex-Proof Electromagnet, continuation

The electromagnet requires a counter plate. It has to be ordered separately.

Depending on the mounting possibilities of magnet and counter plate different types of counter plates are available. They differ in respect of height (distance between mounting plate and counter plate), angle of inclination and type of suspension. The most used model is the flexible counter plate, part no. 040026.

Counter Plates for Ex-Proof Electromagnet

Flexible counter plate AP GD 70 G20

part no. 040026

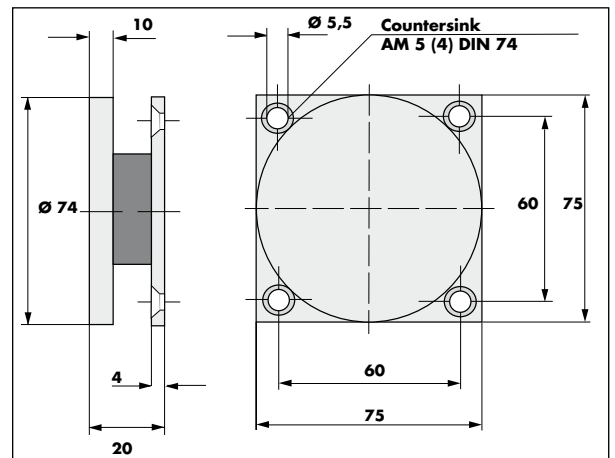
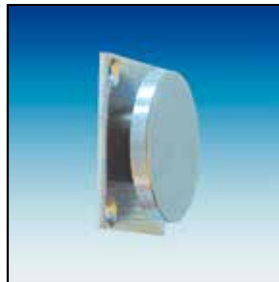

Counter plate with angular joint AP GD 70 W54

part no. 040068

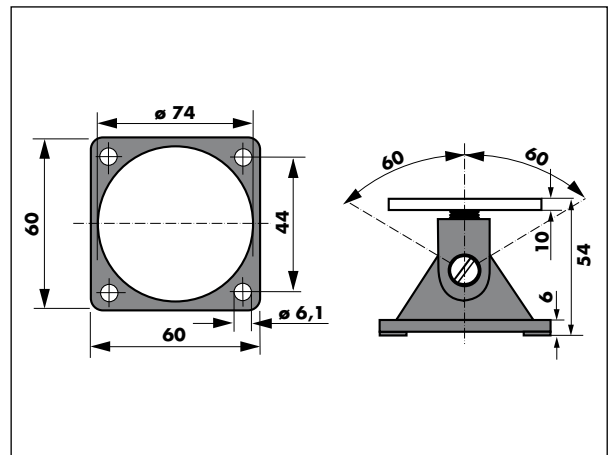
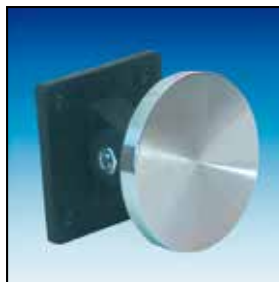

Telescopic counter plate AP GD 70 T84

part no. 040029

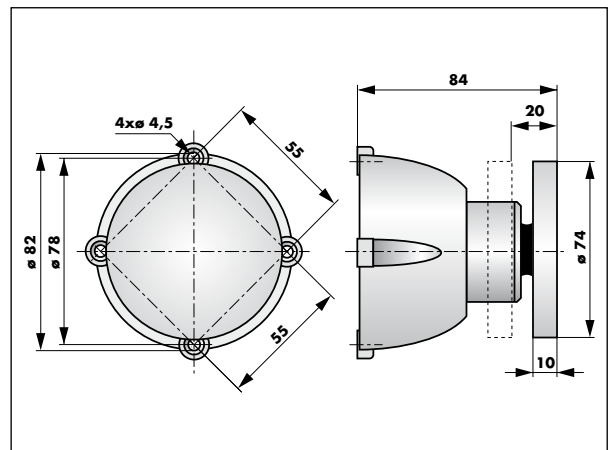



Ex-Proof Interlock Control System - Ex-Proof Electromagnet, continuation

For an easy mounting of the ex-proof magnet and the counter plate on the front side of the door (where the hinges are visible) a mounting kit (part no. 710962) is available.

Once they are mounted, magnet and counter plate will be completely covered when the door is closed. This type of mounting is suitable for clean rooms.

There are also available two additional brackets (part no. 710963) which allow to integrate the ex-proof feedback contact (surface type, see next page).

Mounting Kit

The electromagnet EM GD 70 Ex 43m is fixed to the door frame directly above the door. For the flexible counter plate, part no. 040026, the corresponding mounting bracket of the mounting kit is fixed on the door. To this is screwed the fastening bracket for the counter plate and to this the counter plate. It has to be made sure that it completely covers the electromagnet. Then the covers are fixed.

The surface of the covers is powder-coated in white (RAL 9010).

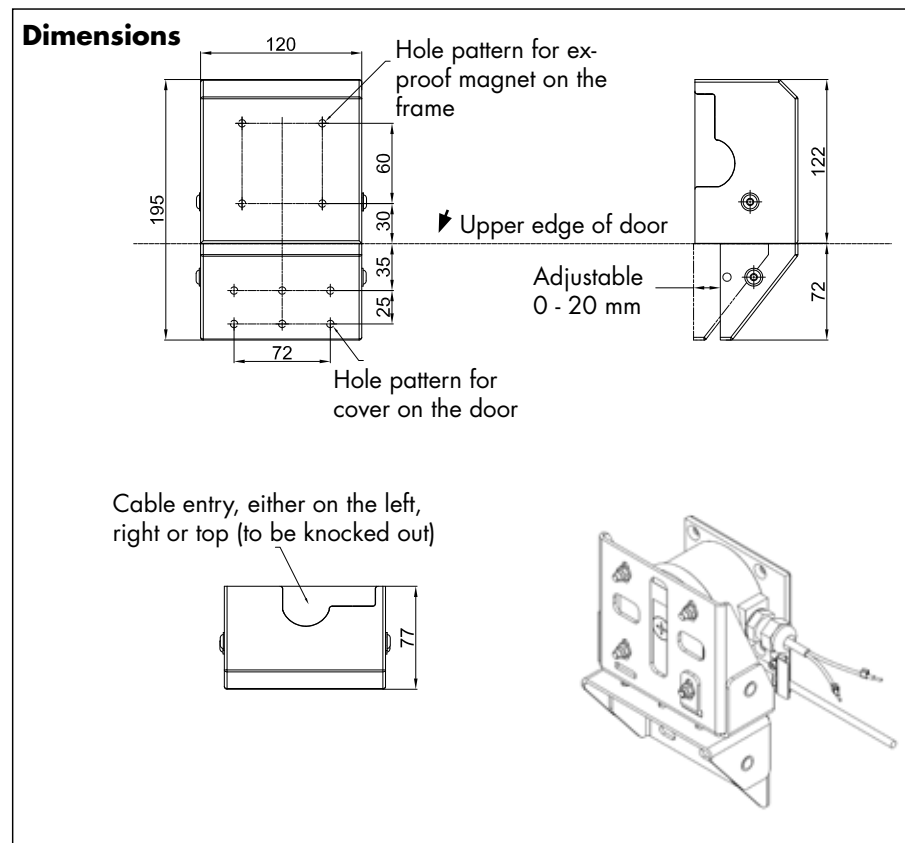
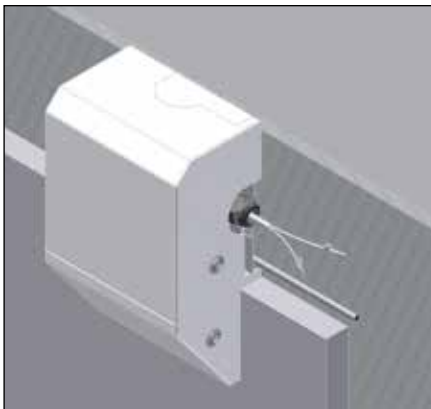

Technical Data / Components Included

Material	stainless steel AISI 430
Finish	powder-coated in white RAL 9010
Components 710962	fixing bracket counter plate, fixing bracket door, cover for ex-proof magnet, cover for bracket on door
Components 710963	mounting plate for feedback contact, fixing bracket for actuating magnet



Ex-Proof Interlock Control System - Ex-Proof Electromagnet, continuation

The ex-proof electromagnet has to be completed by a separate, ex-proof feedback contact. It usually consists of a magnetic switch and the corresponding actuating magnet. The feedback contact has to be actuated when the door is completely closed.

The feedback contact is connected directly to the provided clamps in the SK central controller.

Ex-Proof Feedback Contact, Surface Type

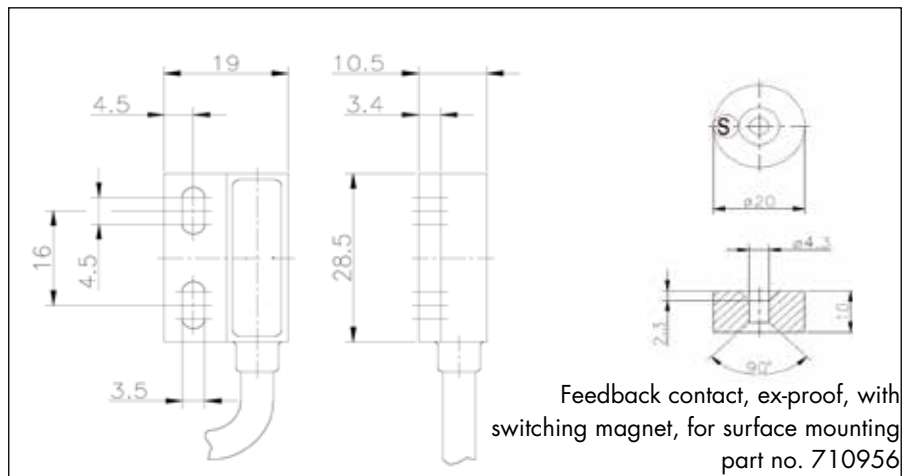

Ex-Proof Feedback Contact, Flush Type

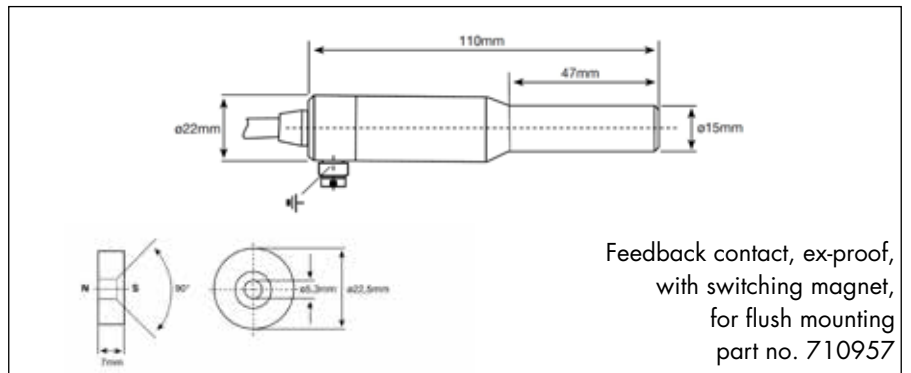

Technical Data

	Feedback contact surface, 710956	Feedback contact flush, 710957
Switching contact	1 make/break contact	1 make/break contact
Switching capacity	max. 3 W/VA	max. 50 W/VA
Switching voltage	30 V AC/DC	max. 250 V AC/DC
Switching current	max. 200 mA	max. 1.5 A
Operating temperature	-40 to +70 °C	-20 to +70 °C
Casing	plastics	nickel-plated brass
Connection cable	15 m, 3 x 0.34 mm ²	15 m, 4 x 0.75 mm ²
Ex-protection	II 2G Ex mb IIC T6 Gb	II 2G EEx m II T6
Switching distance	15 mm	8 mm



Ex-Proof Interlock Control System - Order Information

On this page you will find a summary of the part numbers of all components of the ex-proof Dictator interlock control system. If doors outside the hazardous area should be integrated in the interlock system, the corresponding part numbers will be found in the information about the peripheral or central system.

Other accessories:

- Power packs page 08.071.00 et sqq.

Order Information Terminals

(see page 08.031.00)

SK Central Controller

(see page 08.029.00)

Ex-Proof Electromagnet with Accessories

(see page 08.032.00 and following)

Operating terminal BTZoN EX with connection cable	5 m	part no. 710950
Operating terminal BTZoN EX with connection cable	10 m	part no. 710950-10
Operating terminal BTZoN EX with connection cable	15 m	part no. 710950-15
Operating terminal BTZ EX with connect. cable, LNA	5 m	part no. 710955
Operating terminal BTZ EX with connect. cable, LNA	10 m	part no. 710955-10
Operating terminal BTZ EX with connect. cable, LNA	15 m	part no. 710955-15
SK central controller, no EX casing, 2 doors		part no. 710924
SK central controller, no EX casing, 3 doors		part no. 710924-3
SK central controller, no EX casing, 4 doors		part no. 710924-4
SK central controller, no EX casing, 5 doors		part no. 710924-5
SK central controller, <u>in</u> EX casing, 2 doors		part no. 710965
SK central controller, <u>in</u> EX casing, 3 doors		part no. 710966
SK central controller, <u>in</u> EX casing, 4 doors		part no. 710967
SK central controller, <u>in</u> EX casing, 5 doors		part no. 710968
Additional circuit board (LAN module) for connection to facility management system, to be retrofitted in production		part no. 710954
Electromagnet EM GD 70 Ex43m, 1450 N EEx m II T6, length of connection cable	5 m	part no. 040156-05
Electromagnet EM GD 70 Ex43m, 1450 N EEx m II T6, length of connection cable	10 m	part no. 040156-10
Electromagnet EM GD 70 Ex43m, 1450 N EEx m II T6, length of connection cable	15 m	part no. 040156-15
Counter plate for electromagnet AP GD 70 G20		part no. 040026
Counter plate for electromagnet AP GD 70 W54		part no. 040068
Counter plate for electromagnet AP GD 70 T84		part no. 040029
Mounting kit for ex-proof electromagnet		part no. 710962
Feedback contact (surface) bracket for mounting kit		part no. 710963
Ex-proof feedback contact, surface mounting		part no. 710956
Ex-proof feedback contact, flush mounting		part no. 710957
Adaptor from RJ45 jack to 8-pin screw terminal incl. 250 mm of flat cable with RJ45 connectors		part no. 710964



Interlock Control System for Flush Fitted Switch Boxes or Pattresses SP - Overview

In areas which require an interlock control system but where the door terminals don't have to meet extremely high requirements regarding the suitability for clean rooms, the components of the door terminals can also be integrated in the switch series LS 990 of the company Jung.

Basic Set-up

The structure of the version for the switch boxes SP is similar to the one of the ex-proof interlock control system. All control boards are located in the central controller. The individual components of the "door terminals" and the locking devices as bar magnets or electric strikes are connected directly in the SK central controller.

The necessary wiring and the electrical connection have to be effected on site by the customer. This offers the highest possible flexibility of the system.

The power pack supplying the power is ready for plug-in. Its safety plug is plugged in a socket on site. In the SK central controller is provided a socket for the power cable of the power pack.

The operating key, the LED light for indicating the door status and, if necessary, the emergency-open switch are inserted in the switch box/patress series LS 990 for flush mounting of the company Jung. Depending on the project single frames or frames for up to 5 switches can be used.

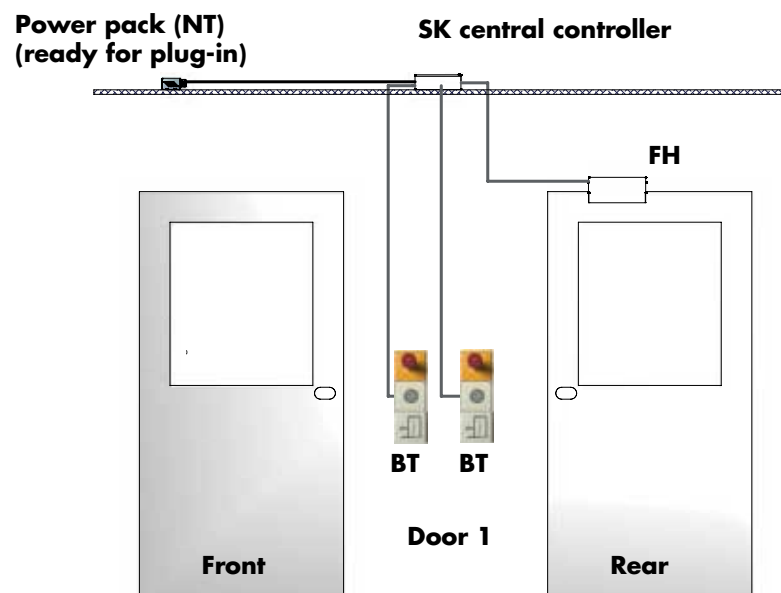

Legend:

FH = bar magnet or electric strike

BT = operating terminal, composed of variable components

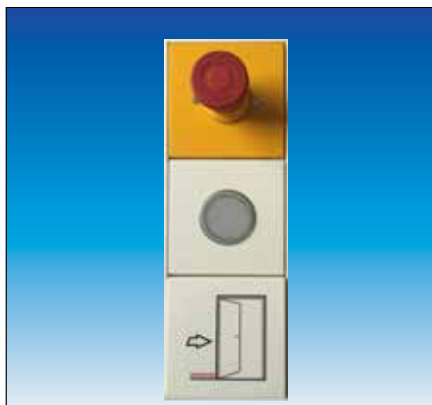

Interlock Control System for Flush Fitted Switch Boxes or Pattresses SP - Components

If necessary, this interlock control system also allows to integrate components of the peripheral or central system. In this case a central controller RJ or a distribution box of the peripheral system are connected to the SK central controller.

System Components

SK Central controller

Per system one SK central controller is needed. It is intended for the connection of cables provided on site.

Usually it can control up to 5 doors. However, it is possible to enlarge the system to a maximum of 8 doors by connecting another SK central controller.

In addition it is also possible to integrate in the interlock control system for switch boxes SP components of the peripheral system. In this case a distribution box of the peripheral system (see pages 08.015.00 et sq.) is connected which allows to control 3 more doors with each a control terminal of the peripheral system and if required an operating terminal BT3 - see pages 08.013.00 et sq.). Another option is to connect a pluggable central controller RJ (see pages 08.021.00 et sqq.) together with the operating terminals BTZ and BT3.

Operating terminals

They are individually combined per door. Components are the Jung switch series LS 990, a switch for releasing the door, an emergency-open switch on a yellow faceplate and a light sign fitted in a faceplate.

Central power pack

The 24 VDC power supply of the SK central controller is provided by a power pack. It is available either with a power of 2.7 A or 5 A. The power pack is furnished ready for mounting with a mains cable with safety plug and a 2 m long 24 VDC cable with 6-pin connector to the SK central controller, i.e. it doesn't have to be opened for connection.

Door locking device

For locking the door a great choice of bar magnets and electric strikes is available (see catalogue beginning on page 08.047.00). It is important that the locking devices used have a potential-free feedback contact.

Time-delayed opening

In case certain doors of the interlock system shall be released only after a delay, this can be adjusted directly in the SK central controller. The remaining time, however, is not indicated in the interlock.

Information about **more components** can be found on the pages about the peripheral and the central system and the additional components.

It is also possible to connect components of other manufacturers (e.g. **emergency exit terminals** and **electric strikes**). Connection diagrams can be found in the manual or are available on request.

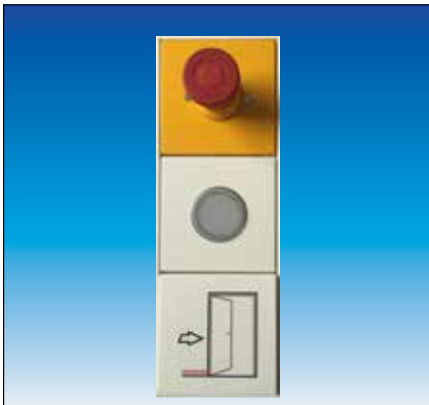

Interlock Control System for Flush Fitted Switch Boxes or Pattresses SP - SK Central Controller

The interlock control system for flush fitted switch boxes SP combines all electrically relevant parts in the SK central controller. The operating terminals are connected by screw terminals.

The standard version provides 2 control boards for 2 doors. In case the interlock control system consists of more doors, the SK central controller will be furnished with the necessary number of control boards.

Structure

The SK central controller is designed for systems with maximum 5 doors. If necessary, the system can be enlarged to maximum 8 doors by adding an additional SK central controller. The SK central controller contains a basic circuit board on which are plugged the control boards for the individual doors. Above every control board are situated 3 terminal strips each:

- KL 1: connection of the locking device (bar magnet or electric strike)
- KL 6: connection of the operating keys and the light signs of the corresponding terminals
- KL 11: connection of the emergency-open switch

More information about the structure, functions and additional options can be found beginning on page 08.029.00.

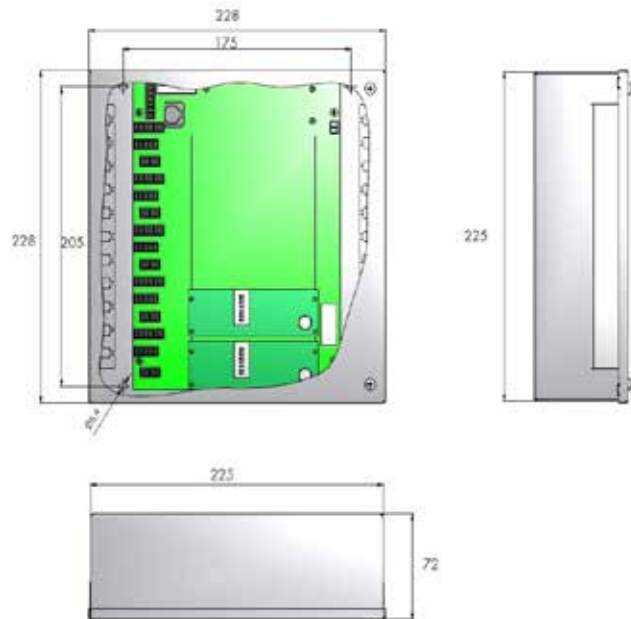

Technical Data

Voltage	24 VDC +/-15 %
Power consumption basic version for 2 doors	100 mA
Power consumption per additional door	50 mA
Power consumption relay for global emergency-open	30 mA
Power consumption LAN module	100 mA
IP rating	IP 20
Operating temperature	-10 °C to +40 °C
Material casing	hot-dip galvanised sheet steel
Max. cable length to terminals/locking devices	15 m



Interlock Control System for Flush Fitted Switch Boxes or Pattresses SP - Components "Operating Terminals"

The operating terminals of the system for switch boxes SP are combined individually and assembled on site. This offers the highest possible flexibility. The SP system is intended for mounting into flush-mounted boxes.

The flush switch boxes should have a diameter of Ø 60 mm and a depth of 40 - 45 mm.

Components

For the **operating terminals** the following **components** are available:

- **Frames of the Jung switch series LS 990** (colour alpine white)
Depending on the number of elements of the operating terminal (with/without emergency-open switch), usually the double or triple frame will be used. To prevent misuse, it is however also possible to locate e.g. the emergency-open switch separately from the normal operating terminal in a single frame.
- **Insert Emergency-Open Switch**
To make the emergency-open switch contrast optically, it is furnished with a yellow faceplate. The emergency-open switch is illuminated. It can be secured against misuse by a cover which is prepared for a lead seal (see page 08.045.00).
- **Faceplate (colour alpine white) with light sign green/red**
The light sign is inserted in a faceplate with a corresponding hole. Depending on the situation, whether the door may be opened or whether another opened door prevents its opening, the light is green or red.
- **Switch for opening the door**
The rocker of the switch shows an icon "open door" and the DICTATOR Logo.



- The wiring and connection of all components has to be provided on site.

Technical Data

Light sign	LED 22, bicolor green/red
Power consumption light sign	24 VDC +15 %, 13 mA (green), 17 mA (red)
Electrical connection light sign	3 x blade terminals 2,8 x 0,5 mm
Emergency-open switch	mushroom-type push-to-lock
Power consumption emergency-open	24 VDC, 30 mA
Emergency-open switch contact set (capacity)	1 break contact, 1 make contact (3 A at 24 VDC)
Electrical connection emergency-open switch	2 x blade terminals 2,8 x 0,5 mm
Operating temperature	-10 °C to +40 °C

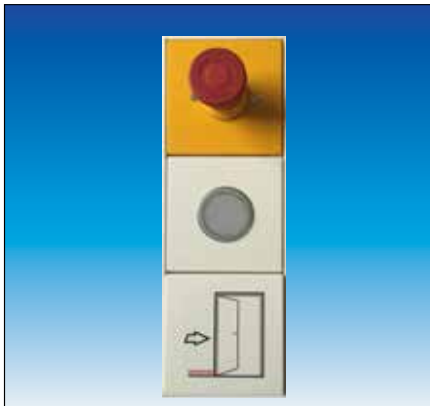

Interlock Control System for Flush Fitted Switch Boxes or Pattresses SP - Order Information

On this page you will find a summary of the part numbers of all components of the DICTATOR interlock control system for flush fitted switch boxes SP.

Other accessories:

- Power packs

page 08.071.00 et sqq.

Order Information Components Operating Terminals

(see page 08.040.00)

SK Central Controller

(see page 08.039.00)

Frame Jung switch series LS 990 alpine white, single	part no. 711011
Frame Jung switch series LS 990 alpine white, double	part no. 711012
Frame Jung switch series LS 990 alpine white, triple	part no. 711013
Emergency-open switch, illuminated with yellow faceplate	part no. 711006
Light sign red/green with faceplate alpine white	part no. 711003
Operating switch alpine white with icon "open door"	part no. 711000
SK central controller, 2 doors	part no. 710924
SK central controller, 3 doors	part no. 710924-3
SK central controller, 4 doors	part no. 710924-4
SK central controller, 5 doors	part no. 710924-5
Additional relay for global emergency-open, retrofittable, for central controller	part no. 710953
Additional circuit board (LAN module) for connection to facility management system, to be retrofitted in production	part no. 710954



Interlock Control System - Emergency Exit Terminal

The DICTATOR interlock control system provides a terminal designed especially for doors in emergency exits. These doors are equipped both with the normal control terminal and an additional emergency exit terminal. This terminal only serves for unlocking the door during an emergency. Normally the interlock door is operated by the control terminal (without emergency-open switch).

The emergency exit terminal has been tested by the German TÜV Thüringen and is approved for its use on emergency exit doors (German standard for electrical locking systems on emergency exits EltVTR), certificate no. P-3250/08.

Dimensions

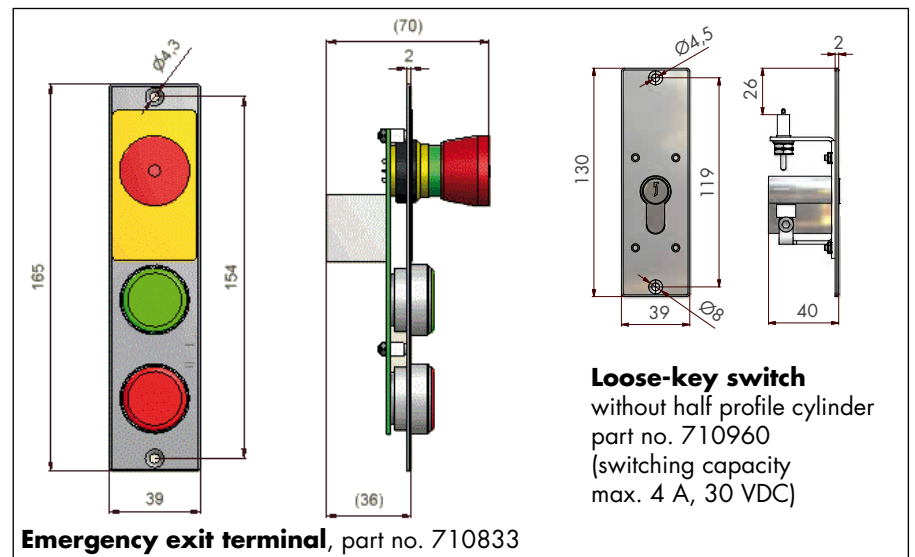

Functioning

The emergency-open switch of the emergency exit terminal permits to unlock the door of the interlock system in case of an emergency. The used locking device has to be an approved one (see DICTATOR bar magnets starting on page 08.047.00, approved magnets are marked with *, or electric strikes on pages 08.064.00 and following). The power supply of the connected bar magnet is interrupted and the door unlocked.

The emergency exit terminal is provided with contacts for an external signal (siren, lamp, horn), even supplying a power of up to max. 1.4 A for the signal. (ATTENTION: this power consumption has to be taken into account when calculating the required performance of the power pack).

The emergency-open command can also be given directly by a facility management centre. In this case, however, the system must be configured for a global emergency-open.

The door status is indicated by the two lamps on the terminal:

Red LED on: Door is locked electrically.

Green LED on: Door is released.

After an emergency unlocking the door has to be locked again by a separate switching device within splitting distance of the door like for instance the loose-key switch with stainless steel front plate (AISI 304), part no. 710960 (see illustration on top and left). The half profile cylinder (according to DIN 18252) has to be provided by the customer.

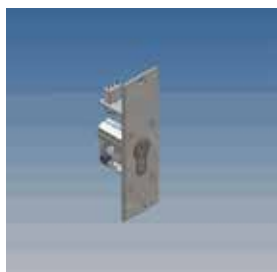

Technical Data Emergency Exit Terminal

Power consumption	24 VDC, approx. 80 mA
IP rating	IP 20
Operating temperature	-10 °C to +40 °C
Emergency-open contact set (capacity)	2 NC contacts: 2.8 A
Input signal from hazard alert system	NC contact
Output to signal (horn etc.)	24 VDC, max. 1.4 A

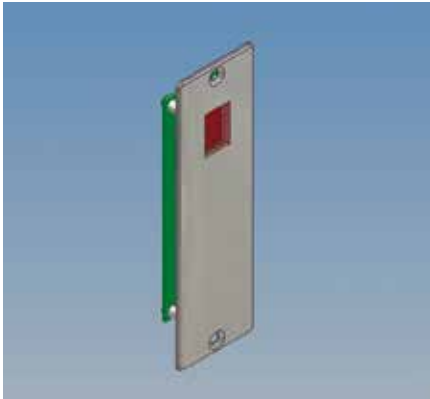

Interlock Control System - Time Control Unit

Some interlock systems require that some doors open only after a certain time delay, e.g. if the quality/temperature of the air in the interlock must reach a certain level before the door to the clean room may open. The DICTATOR time control unit permits the locking of max. 6 clean room doors against up to 6 "blackroom" doors. If one or several of the "blackroom" doors are opened during the locking time, the time control unit starts the count-down again. Only when the adjusted time has elapsed, the door to the clean room can be opened.

Functioning / Dimensions

The type of door (clean room or blackroom) is determined by the connection of the control terminals to different terminal strips of the time control unit.

The required period (16 different values possible) is adjusted in the time control unit with the help of 4 DIP switches. If a time different from the 16 adjusted periods is required, this has to be indicated in the order as it has to be programmed in production.

The time control unit has a 7-segment display and an additional dot. If the time control unit is on, the dot of the display lights up. When the time control unit is activated by one of the connected terminals, the dot starts flashing (one flash per second). When all blackroom doors are closed the countdown starts. The time control unit divides the adjusted period in 10 intervals and the display counts down from 9 to 0, thus indicating the remaining time during which the doors stay locked.

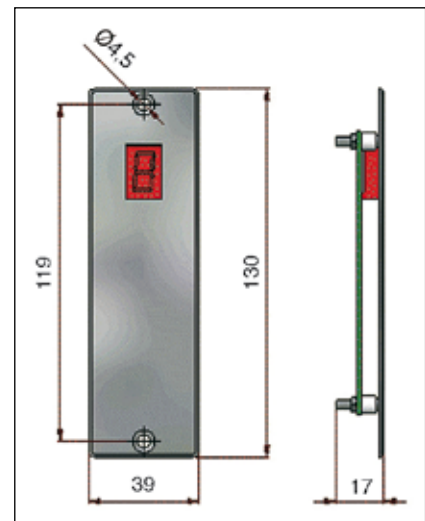

Models / Components

It is possible to connect up to 6 additional displays (part no. 710805) to the time control unit. Independent of the amount of additional displays there is always required one extender circuit module (part no. 710808).

The time control unit is connected with a normal cable directly to the distribution box. The extender circuit module for the additional displays is simply plugged on the circuit board of the time control unit (ATTENTION: this changes the construction depth to a minimum depth of 70 mm!). The **additional displays** are connected with the connection cables, part no. 710809 or 710810. If they are not long enough, the connection can also be done on site. In this case a set of connection plugs, part no. 710811, is required, one for each module/additional display.

Technical Data

Power consumption time control unit	24 VDC, max. 20 mA
Power consumption extender circuit module	24 VDC, max. 2 mA
Power consumption additional display	24 VDC, max. 10 mA
IP rating	IP 20
Operating temperature	-10 °C to +40 °C
Periods	16 different periods adjustable (0, 15, 20, 25, 30, 35, 40, 50, 60, 120, 180, 240, 300, 420, 540, 660 seconds) max. time lag 2.75 hours
Number of controllable doors	6 clean room and max. 6 "blackroom" doors

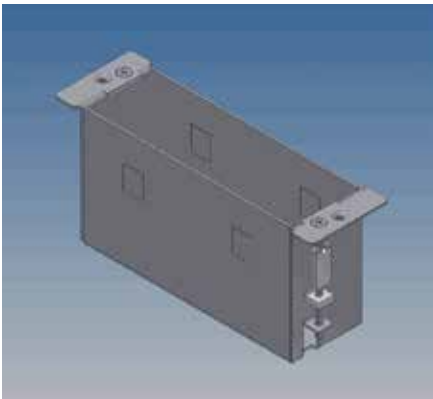

Interlock Control System - Installation Components

For the installation of the different terminals there are available suitable flush and surface boxes.

Furthermore, the terminals with emergency-open switch can be protected against unauthorised activating of this switch by a cover that is prepared for a lead seal.

Flush and Surface Boxes

Generally the control and operating terminals, the time control unit and the loose-key switch (see page 08.043.00) are intended for flush mounting in the hollow profiles of the interlock doors. If necessary, a corresponding flush box is available (part no. 710829).

But the terminals can also be mounted on the surface. The surface box has the IP rating IP 65 and is powder-coated. It is available in two colours:

- white RAL 9010 (part no. 710831)
- white aluminium, metallic, RAL 9006 (part no. 710832).

Also for the emergency exit terminal a flush box (part no. 710834) and a surface box in white RAL 9010 (part no. 710835) are available.

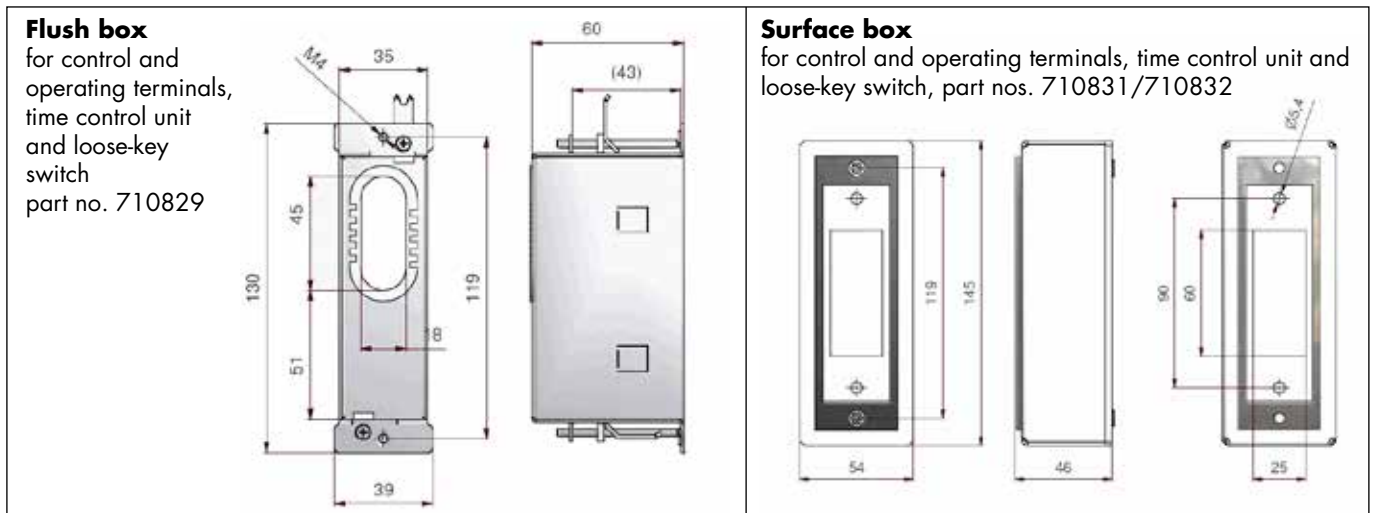

Cover Prepared for a Lead Seal

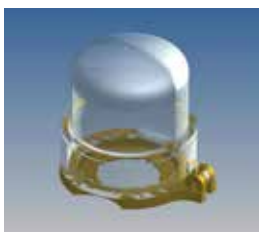

In case the emergency-open switches in an interlock control system are again and again misused, they can be protected by a cover that is prepared for a lead seal (part no. 710839). This cover can be retrofitted and is from transparent, UV resistant plastics with a yellow collar for fixing.

This cover has a predetermined separation area and can be reused after the emergency-open switch has been activated.

The lead seal is not included in the delivery.

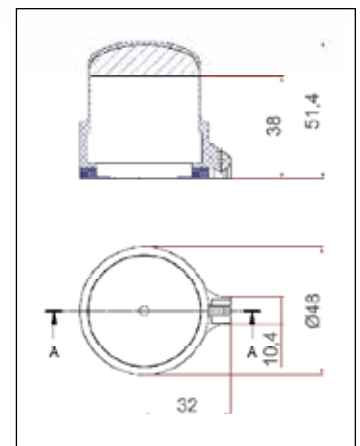



Additional Components for Peripheral and Central Interlock Control System - Order Information

On this page you will find the part numbers of all the additional components for the peripheral and central DICTATOR interlock control system mentioned on the previous pages.

Order Information Emergency Exit Terminal Time Control Unit

(see page 08.044.00)

Mounting Components

(see page 08.045.00)

Emergency exit terminal FT P	part no. 710833
Loose-key switch for emergency exit terminal	part no. 710960
Time control unit ZS	part no. 710805
Additional display ZA for the time control unit	part no. 710806
Extender circuit module for additional displays	part no. 710808
Surface box P for the control/operating terminal, white, RAL 9010	part no. 710829
Surface box P for the control/operating terminal, white, RAL 9010	part no. 710831
Surface box P for control/operating terminal, metallic, RAL 9006	part no. 710832
Flush box P for emergency exit terminal	part no. 710834
Surface box P for emergency exit terminal, white, RAL 9010	part no. 710835
Cover prepared for a lead seal	part no. 710839

Bar Magnets

The bar magnets are used as **locking device** in access and emergency exit doors e.g. in interlock control systems. Because of their relatively easy installation they are also suited for retrofitting.

All bar magnets meet the requirements of the EN 1154.

In the locking or interlock control systems only the types with feedback contacts may be used.

There exists a large variety of bar magnets: surface type, for flush mounting, double magnet for two-leaved doors (only surface type). Part of this program is shown on the following pages.



Product Line

Voltage	12 or 24 VDC \pm 10 %, adjustable on most types
Power consumption	see technical data of the different types
Holding force	1000 N - 4600 N
Duty cycle	100 %
Operating temperature	-10 °C to +55 °C
Remanence	0 N (due to release pin)
Finish	zinc-plated, special types in stainless steel
IP rating	IP 42, special types also IP 67
Feedback contact	with and without Hall sensor or reed switch



Bar Magnet FH200I
1450 N Holding Force, IP 67, Surface Type

The FH200I bar magnet with protection IP 67 is especially designed for the use in exterior installations or humid surroundings. The casing is made of stainless steel and is waterproof. The counter plate is available either in zinc-plated steel or in stainless steel. It is always furnished with a feedback contact. The FH200I has not been tested for the use on emergency exit doors.

The bar magnet can be connected either to 12 or 24 VDC. The adjustment of the required voltage is done simply by a different connection of the 4 leads of the connection cable. It can be installed on the frame both from the front and from below. Information about mounting accessories you will find on page 08.057.00.

Dimensions FH200I

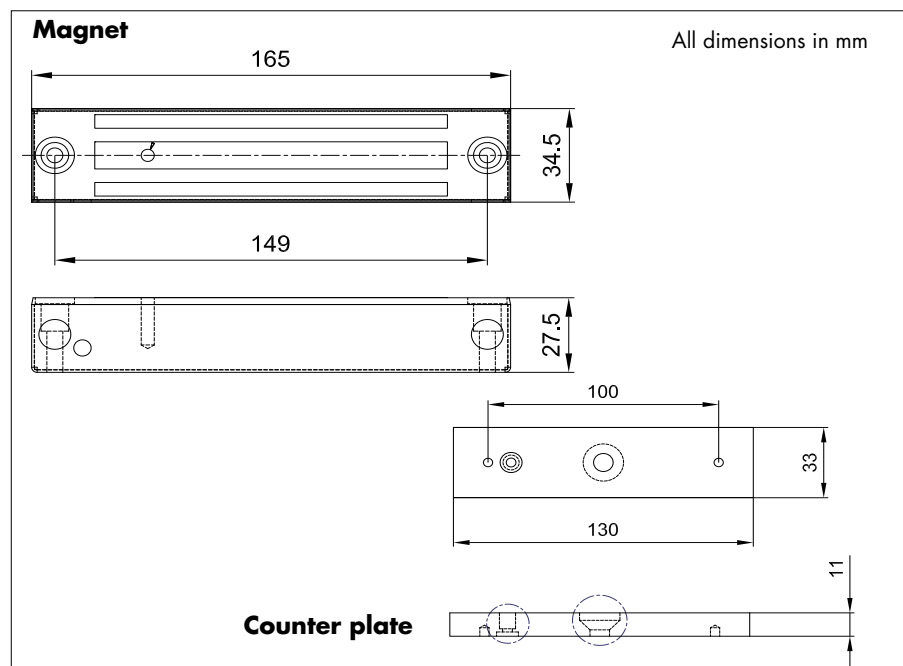

Technical Data

Voltage	12 VDC ±10 %	24 VDC ±10 %
Power consumption	500 mA	250 mA
Holding force	1450 N	
Duty cycle	100 %	
Operating temperature	-10 °C to +55 °C	
Remanence	0 N (due to release pin)	
Finish magnet	stainless steel	
Material counter plate	zinc-plated steel or stainless steel (1.4021/X20Cr13)	
IP rating	IP 67	
Feedback contact	with reed switch	
Electrical connection	approx. 1 m connection cable	
Cable entry	at the top	

Order Information

Bar magnet FH200I	part no. 040665SET
+ zinc-plated counter plate, 2 mounting brackets for top and front mounting, connection cable	
Bar magnet FH200I	part no. 040664SET
+ stainless steel counter plate, 2 mounting brackets for top + front mounting, connection cable	



Bar Magnet FH300 2000 N Holding Force, Surface Type

The bar magnet FH300 is available with or without the feedback contact Hall sensor. The type with Hall sensor is designed for the use in door locking/interlock control systems as it provides the required information on the door (locked, unlocked).

The FH300 is also available as double magnet for doors with two leaves.

The connection terminals for the electrical wiring are accessible from the front. The bar magnet can be connected either to 12 or 24 VDC. The required voltage is adjusted on the circuit board with jumpers. The cable entry is at the top. Included is a mounting bracket with which the magnet can be fixed to the door frame from below.

Information about mounting accessories you will find on page 08.057.00.

Dimensions FH300

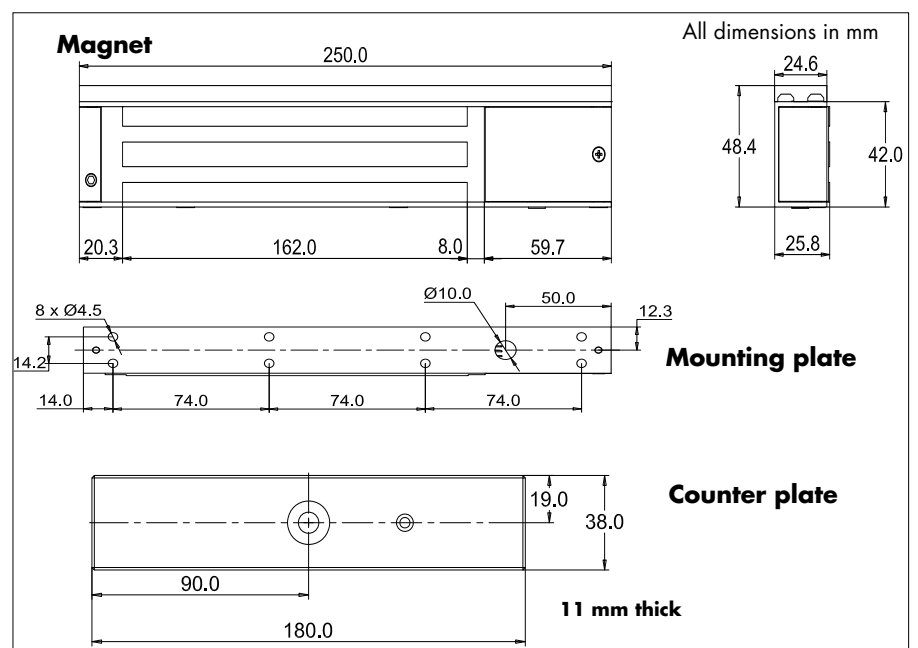

Technical Data

Voltage	12 VDC ±10 %	24 VDC ±10 %
Power consumption	480 mA	240 mA
Holding force	2000 N	
Duty cycle	100 %	
Operating temperature	-10 °C to +55 °C	
Remanence	0 N (due to release pin)	
Finish	magnet zinc-plated / Casing aluminium	
IP rating	IP 42	
Feedback contact	with or without Hall sensor	
LED indication light	all models with Hall sensor also with LED	
Electrical connection	connecting terminal integrated in the magnet	

Order information

Bar magnet FH300 with counter plate	part no. 040670SET
Bar magnet FH300K with Hall sensor, LED, counter plate	part no. 040671SET
Double magnet FH300-2 with counter plate	part no. 040672SET
Double magnet FH300-2K w.Hall sensor, LED, counter plate	part no. 040673SET



**Bar Magnet FH300U
2000 N Holding Force, Flush Mounting**

The bar magnet FH300U is available with and without integrated feedback contact. The type with reed switch is designed for the use in door locking/interlock control systems as it provides the required information on the door (locked, unlocked).

It can be connected either to 12 or 24 VDC. The adjustment of the required voltage is done on the connecting board by the adequate positioning of jumpers.

Dimensions FH300U

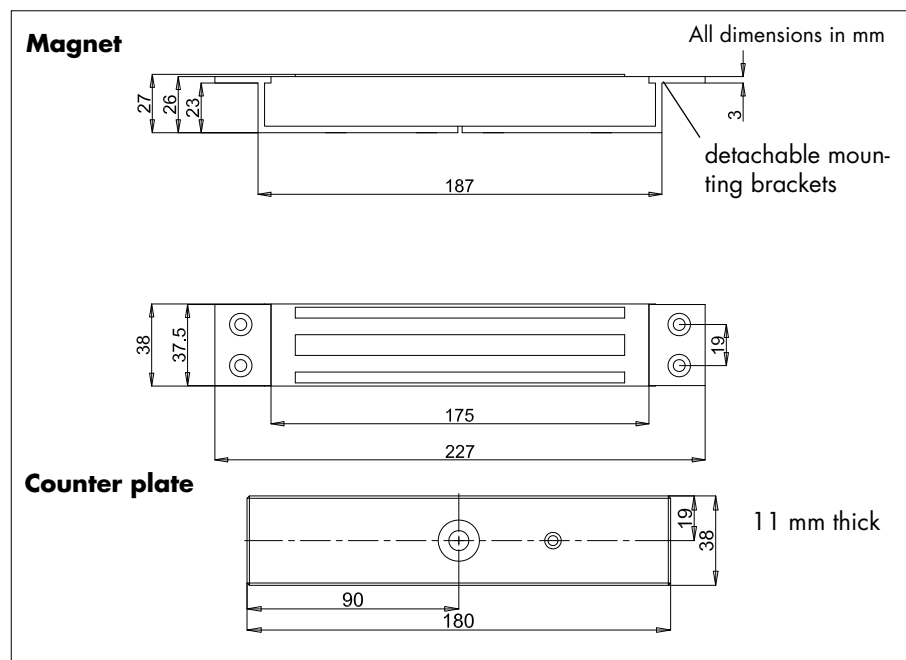

Technical Data

Voltage	12 VDC ±10 %	24 VDC ±10 %
Power consumption	480 mA	240 mA
Holding force	2000 N	
Duty cycle	100 %	
Operating temperature	-10 °C to +55 °C	
Remanence	0 N (due to release pin)	
Finish	zinc-plated	
IP rating	IP 42	
Feedback contact	with or without reed switch	
LED indication light	none	
Electrical connection	connecting terminal	

Order Information

Bar magnet FH300U for flush mounting with counter plate	part no. 040282SET
Bar magnet FH300UK for flush mounting with reed switch and counter plate	part no. 040281SET



Bar Magnet FH300U35 2000 N Holding Force, Flush Mounting

The bar magnet FH300U35 is available with and without integrated feedback contact. The type with reed switch is designed for the use in door locking/interlock control systems as it provides the required information on the door (locked, unlocked). It can be connected either to 12 or 24 VDC. The adjustment of the required voltage is done on the connecting board by the adequate positioning of jumpers. The casing of the FH300U35 is made of stainless steel, the counter plate of zinc-plated steel. Included are two separate mounting plates and two attachment screws of different length. With these screws you may fix the magnet from the rear. The magnet is also available being integrated in an aluminium profile (see page 08.055.00).

Dimensions FH300U35

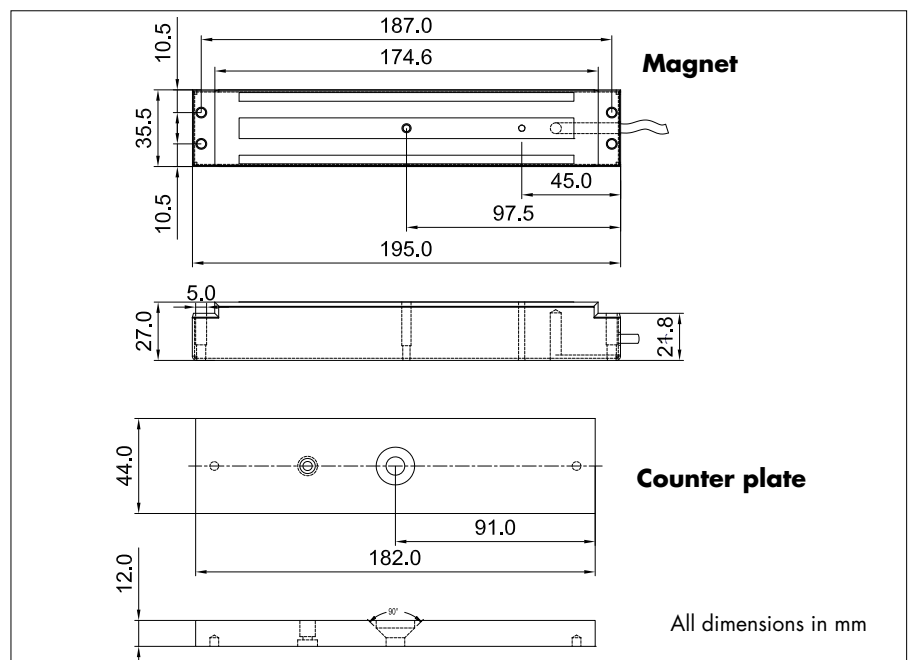

Technical Data

Voltage	12 VDC ±10 %	24 VDC ±10 %
Power consumption	480 mA	240 mA
Holding force	2000 N	
Duty cycle	100 %	
Operating temperature	-10 °C to +55 °C	
Remanence	0 N (due to release pin)	
Finish	magnet stainless steel / Counter plate zinc-plated	
IP rating	IP 42	
Feedback contact	with or without reed switch	
LED indication light	none	
Electrical connection	connecting board	

Order Information

Bar magnet FH300U35 for flush mounting with counter plate	part no. 040283SET
Bar magnet FH300U35K for flush mounting with reed switch and counter plate	part no. 040284SET



**Bar Magnet FH550
4300 N Holding Force, Surface Mounting**

The bar magnet FH550 is available with and without integrated feedback contact (Hall sensor). The type with Hall sensor is designed for the use in door locking/interlock control systems as it provides the required information on the door (locked, unlocked). It is also available as double magnet for doors with two leaves.

The connecting terminal for the electrical wiring is accessible from the front. The bar magnet can be connected either to 12 or 24 VDC. The required voltage is adjusted on the connecting board with jumpers. Included is a mounting bracket with which the magnet can be fixed to the door frame from below.

Information about mounting accessories you will find on page 08.057.00.

Dimensions FH550

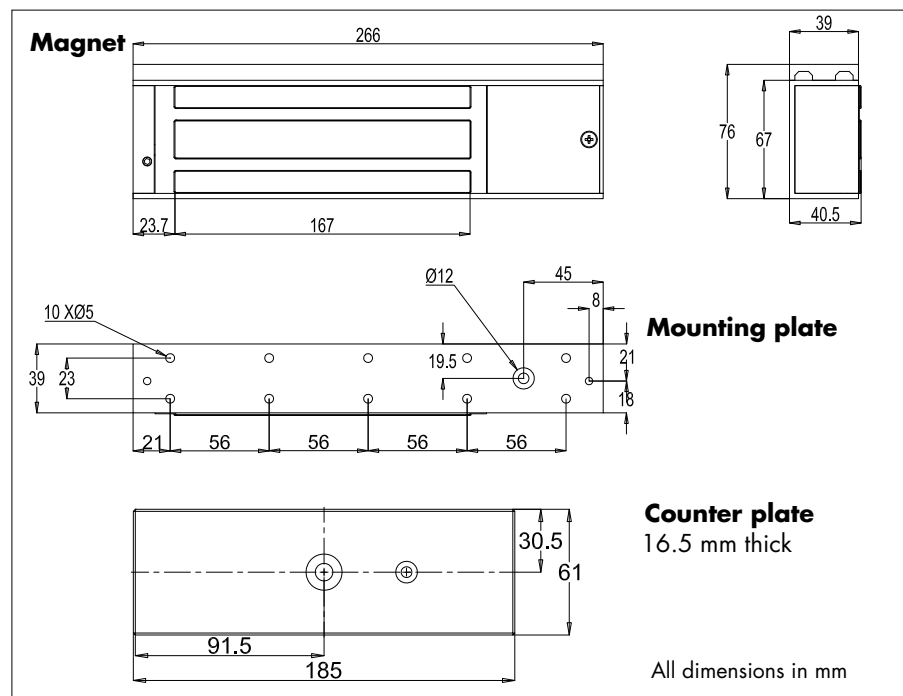

Technical Data

Voltage	12 VDC ±10 %	24 VDC ±10 %
Power consumption	480 mA	240 mA
Holding force	4300 N	
Duty cycle	100 %	
Operating temperature	-10 °C to +55 °C	
Remanence	0 N (due to release pin)	
Finish	magnet zinc-plated / surface casing aluminium	
IP rating	IP 42	
Feedback contact	with and without Hall sensor	
LED indication light	all types with Hall sensor with LED	
Electrical connection	connecting terminals integrated in the magnet	

Order Information

Bar magnet FH550 for surface mounting with counter plate	part no. 040277SET
Bar magnet FH550K with Hall sensor, LED, counter plate	part no. 040285SET
Double magnet FH550-2 with counter plate	part no. 040278SET
Double magnet FH550-2K Hall sensor, LED, counter plate	part no. 040279SET

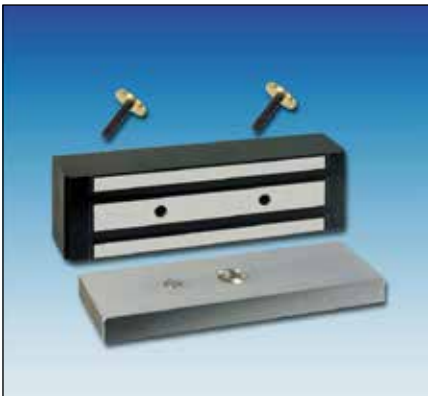

Bar Magnet FH550U 3600 N Holding Force, Flush Mounting

The bar magnet FH550U is available with and without integrated feedback contact. The type with reed switch is designed for the use in door locking/interlock control systems as it provides the required information on the door (locked, unlocked).

The bar magnet can be connected either to 12 or 24 VDC. The required voltage is adjusted on the connecting board with jumpers.

The F550U is being fixed from behind using two attachment screws.

Dimensions FH550U

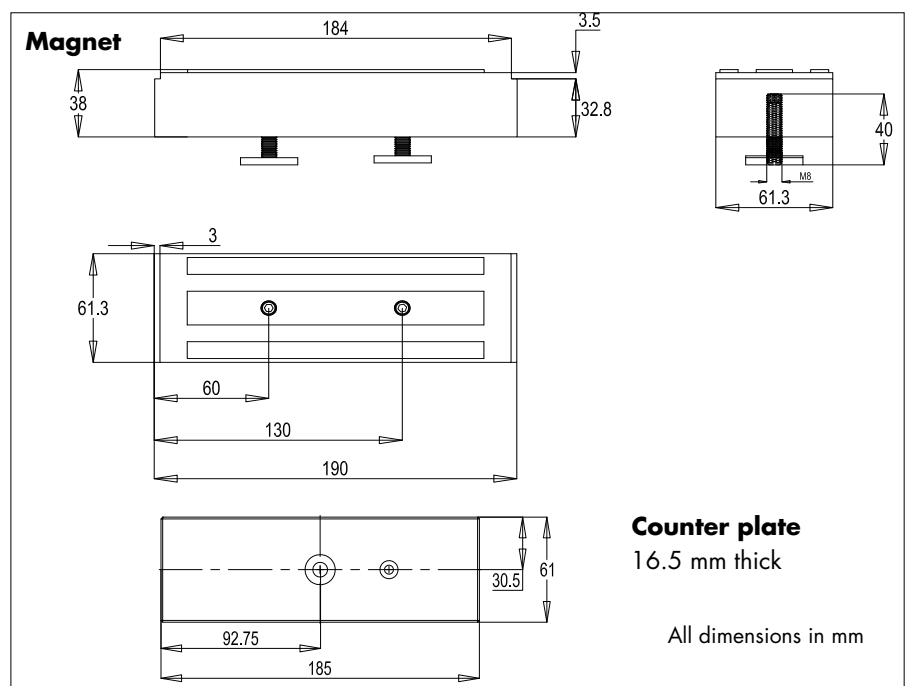

Technical Data

Voltage	12 VDC ±10 %	24 VDC ±10 %
Power consumption	480 mA	240 mA
Holding force	3600 N	
Duty cycle	100 %	
Operating temperature	-10 °C to +55 °C	
Remanence	0 N (due to release pin)	
Finish	zinc-plated	
IP rating	IP 42	
Feedback contact	with or without reed switch	
LED indication light	none	
Electrical connection	connecting board	

Order Information

Bar magnet FH550U for flush mounting with counter plate	part no. 040678SET
Bar magnet FH550UK for flush mounting with reed switch and counter plate	part no. 040679SET

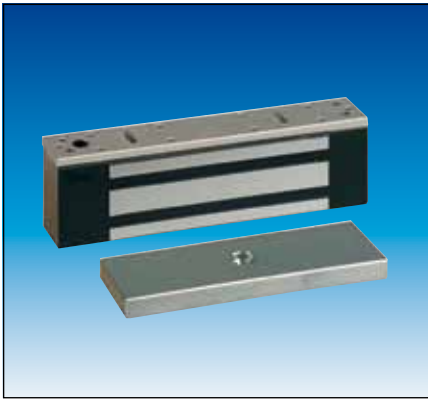

Bar Magnet FH750I
4600 N Holding Force, IP 67, Surface Mounting

The FH750I bar magnet with protection IP 67 is especially designed for the use in exterior installations or humid surroundings. The casing is made of stainless steel and is waterproof. The FH750I is always furnished with a feedback contact (reed switch). It can be connected either to 12 or 24 VDC. The adjustment of the required voltage is done by a different connection of the leads of the connection cable. It can be installed on the frame both from the front and from below. Information about mounting accessories you will find on page 08.057.00.

Dimensions FH750I

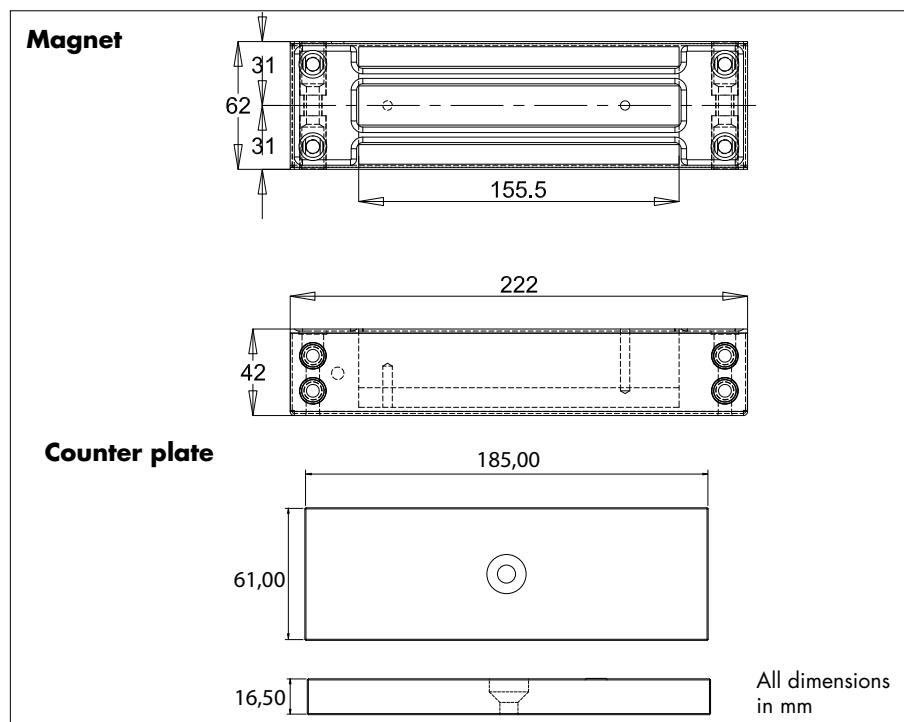

Technical Data

Voltage	12 VDC ± 10 %	24 VDC ± 10 %
Power consumption	500 mA	250 mA
Holding force	4600 N	
Duty cycle	100 %	
Operating temperature	-10 °C to +55 °C	
Remanence	0 N (due to release pin)	
Finish	stainless steel	
IP rating	IP 67	
Feedback contact	with reed switch	
Electrical connection	approx. 1 m connecting cable	
Cable entry	at the top	

Order Information

Bar magnet FH750I	part no. 040680SET
with counter plate, 2 mounting brackets for top + front mounting, connecting cable	



Bar Magnet Device FH300AS400/FH300AS600 2000/4000 N, for Mounting as Door Handle

The bar magnet FH300U35 for flush mounting (see page 08.051.00) is also available integrated in a two-parts aluminium profile ready for mounting. The magnet itself is completely pre-assembled in the profile to be fixed to the door frame. The adjustable counter plate is integrated in the second profile. This profile serves as door handle and is fixed to the door. The installation is simple and doesn't require much time. No screws are visible. On demand, especially for the installation in cleanrooms, we also supply lacquered aluminium profiles.

By default these profiles are available in the following lengths: 400 mm (1 magnet/counter plate integrated), 600 mm (2 magnets/counter plates integrated) and 2200 mm (2 magnets/counter plates).

Dimensions Bar Magnet Device FH300AS

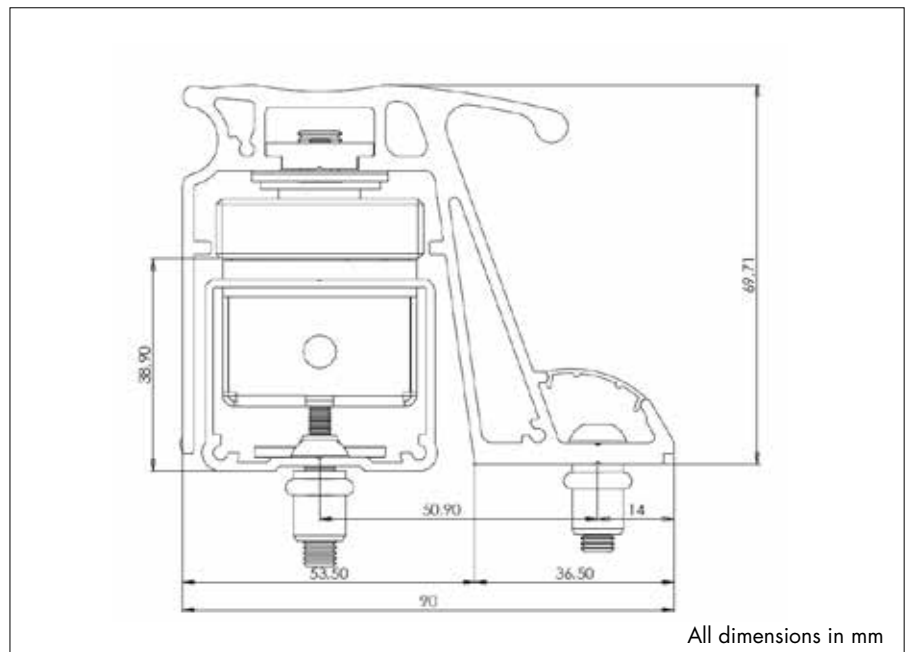

Components

Aluminium profile with 1 or 2 integrated bar magnets FH300U35

Aluminium profile with handle with 1 or 2 integrated counter plates for FH300U35

Fixing screws

Technical Data

Voltage	12 VDC ± 10 %	24 VDC ± 10 %
Power consumption FH300AS400	480 mA	240 mA
FH300AS600/2200	960 mA	480 mA
Holding force FH300AS400	2000 N	
Holding force FH300AS600/2200	4000 N	
Duty cycle	100 %	
Operating temperature	-10 °C to +55 °C	
Remanence	0 N (due to release pin)	
Finish	magnet stainless steel (V2a), counter plate zinc-plated	
IP rating	IP 42	
Feedback contact	with reed switch	
LED indication light	none	
Electrical connection	connecting board, jumper for choosing 12/24 VDC	
Finishing of aluminium profile	satined	



**Bar Magnet Device FH300AS400/FH300AS600
2000/4000 N, as Door Handle, cont.**

To complete the bar magnet device FH300AS on the opposite side of the door we offer the additional profiles P and S. They are particularly used when the aluminium profile AS with the integrated counter plate is to be fixed to the door with through bolts. There are available two types of this additional profile:

- Type S: it is merely a counter plate and serves as cover profile.
- Type P: this profile serves as counter plate and as door handle.

These profiles are available in 400 mm, 600 mm and 2500 mm length. They have a satin finishing, but on demand, especially for the installation in clean rooms, we also supply lacquered aluminium profiles.

**Dimensions
Aluminium Profile for
Opposite Side of Door**

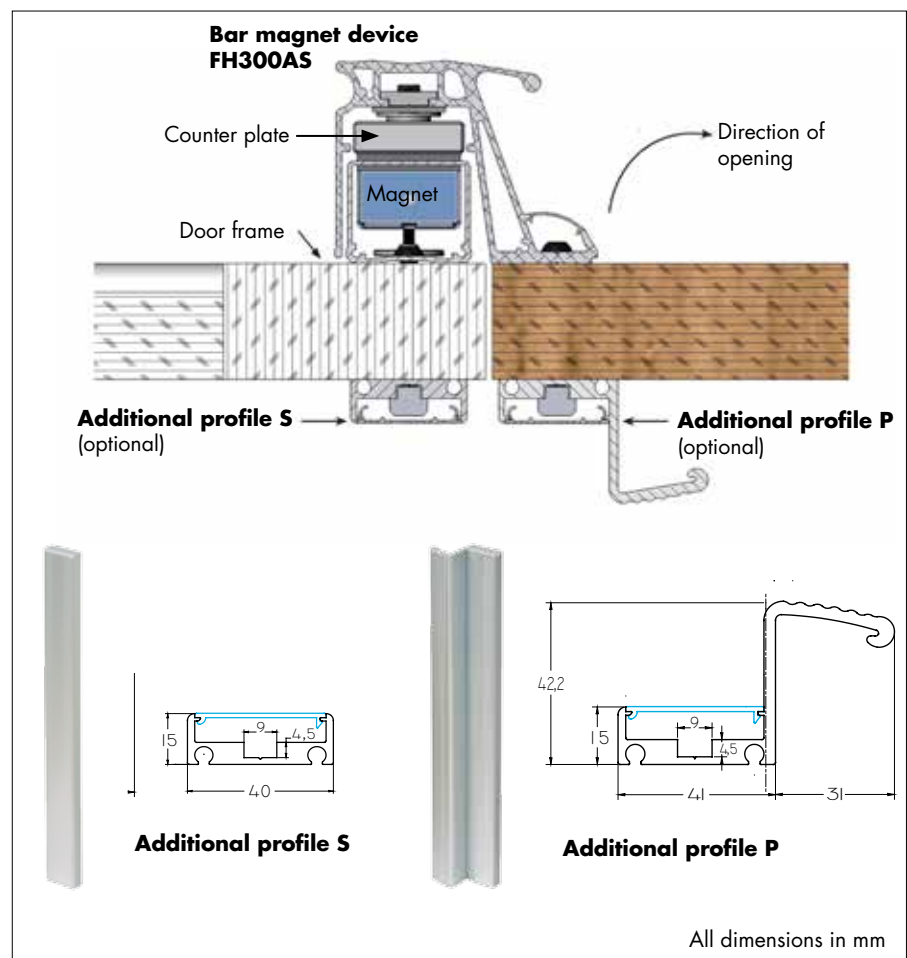

Order Information

Bar magnet device FH300AS400	part no. 041720
Bar magnet device FH300AS600	part no. 041710
Bar magnet device FH300AS2200	part no. 041700
Additional profile S400	part no. 041724
Additional profile S600	part no. 041714
Additional profile S2500	part no. 041704
Additional profile P400	part no. 041722
Additional profile P600	part no. 041712
Additional profile P2500	part no. 041702



Accessories - Mounting Brackets for Surface Mounting

For the installation of the bar magnets we supply different mounting brackets. If any and which type of mounting bracket is needed, depends on the kind of door and where the bar magnet shall be placed.

Below you will find illustrations of the most frequent ways of installation.

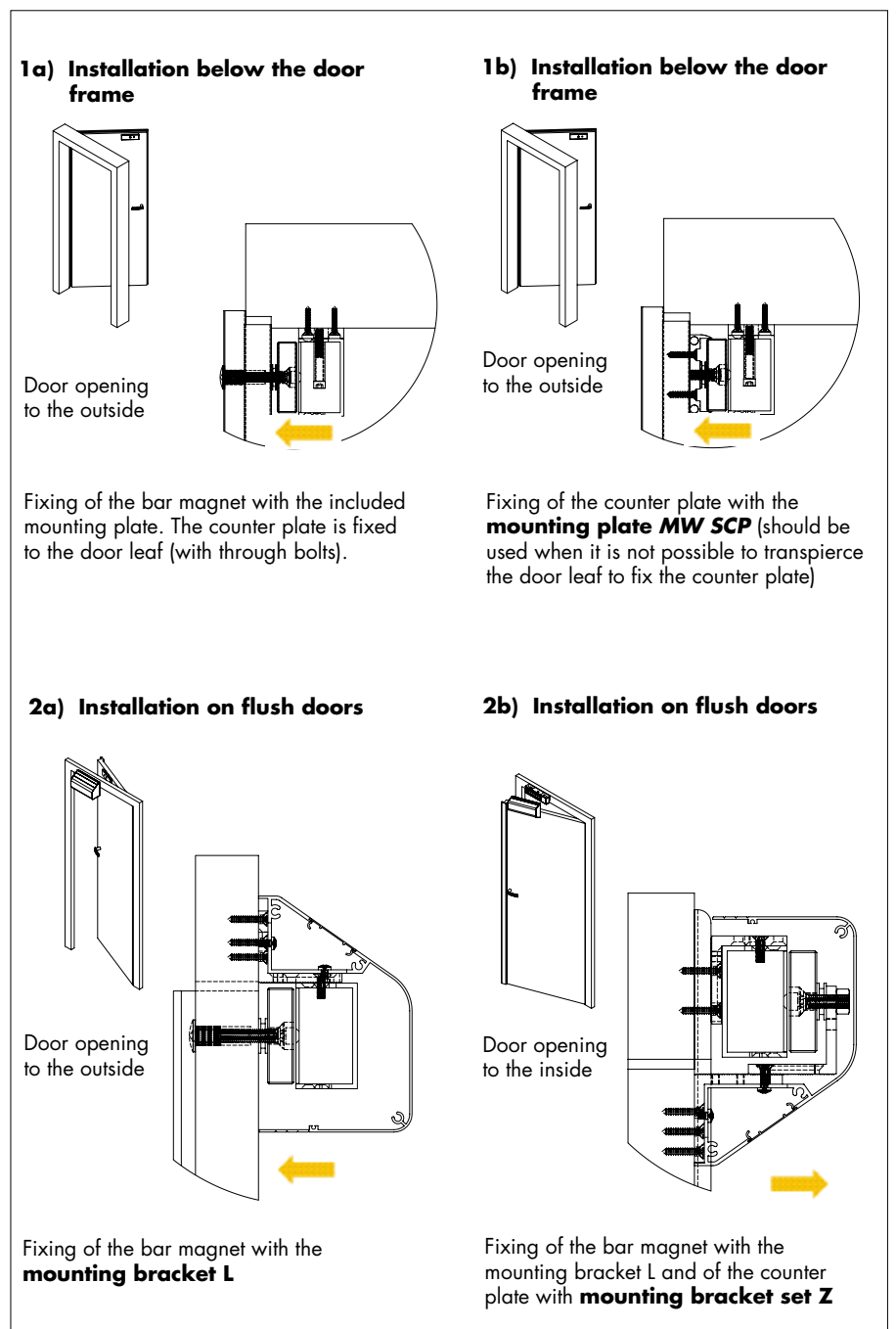



Accessories - Mounting Brackets for Surface Mounting

Below you will find the mounting brackets for the different installation possibilities shown on the previous page. The number in the name indicates for which type of surface bar magnet the mounting bracket is intended, e.g. mounting set MW 550/750SCP: for surface mounting bar magnets FH550 and FH750.

Some of the brackets are suitable for the FH300 as well as for the FH550 (e.g. mounting bracket set MW300/550Z).

Dimensions

Mounting bracket L
Dimensions MW300L
part no. 040674

Dimensions MW550L
part no. 040286

Mounting bracket MW200L, 750L and those for double magnets on demand

Mounting bracket set Z
Dimensions MW300/550Z
part no. 040675

Mounting set MW SCP for the counter plate
Dimensions MW300SCP
part no. 040677

Dimensions MW550/750SCP
part no. 040289

Order Information

Mounting bracket MW200L	part no. 040667
Mounting bracket MW300L	part no. 040674
Mounting bracket MW550L	part no. 040286
Mounting bracket MW750L	part no. 040682
Mounting bracket set MW200Z	part no. 040668
Mounting bracket set MW300/550Z	part no. 040675
Mounting bracket MW750Z	part no. 040683
Mounting set MW300SCP for counter plate	part no. 040677
Mounting set MW550/750SCP for counter plate	part no. 040289

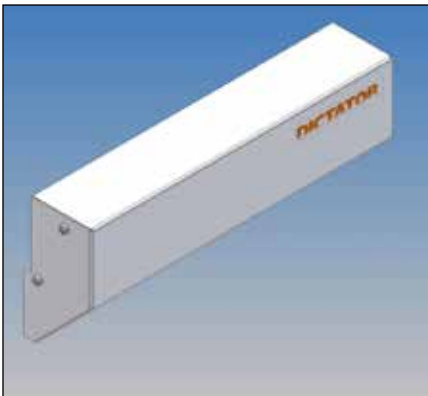

Accessories - Covers

For the surface bar magnets FH300 and FH550 covers are available. They completely cover the bar magnet and the counter plate when the door is closed. For the bar magnets FH550 they can be provided only in aluminium, for the FH300 in aluminium with lateral plastic caps or in powder coated, zinc-plated sheet steel.

Covers can only be used on flush doors with the corresponding mounting brackets (see page 08.057.00, installation on flush doors, 2a and 2b). With the covers from sheet steel 041741/041742 it is absolutely necessary to choose the ones conform to the installation. The covers from aluminium can be used for both installation types.

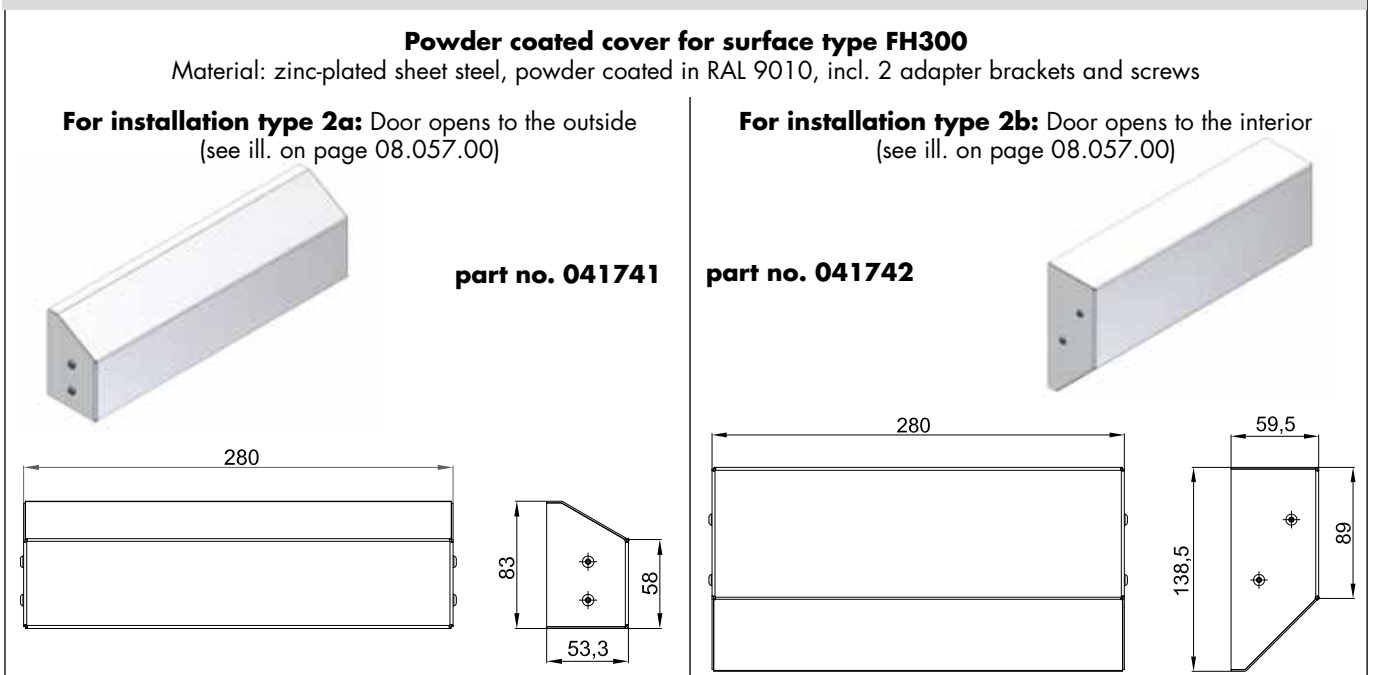
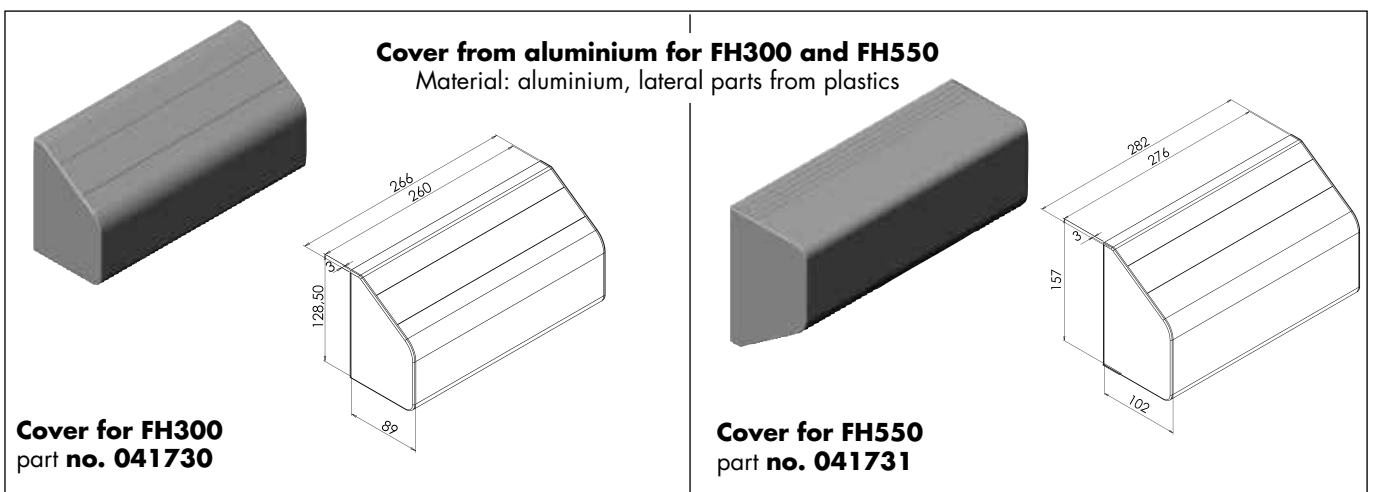

Order Information

Aluminium cover for surface type FH300	part no. 041730
Aluminium cover for surface type FH550	part no. 041731
Powder coated cover for surface FH300 (installation type 2a)	part no. 041741
Powder coated cover for surface FH300 (installation type 2b)	part no. 041742

Door Locks

TVR Door Locking Unit, Electric Strikes, Accessories

Beside the bar magnets there exist several other locking devices. Among these are the TVR door locking system and electric strikes. On the following pages you will find a small choice of the product range.

The TVR1 door locking unit has an extremely low power consumption. The singular combination of an electromagnetic lock and a sturdy locking bolt offers highest safety. Due to the concealed installation the TVR1 door lock is to a large extent safe from damage and manipulation.

A further possibility to keep a door locked are the electric strikes. When used in combination with the DICTATOR interlock control system, you should take care that they are generally unlocked when without power. You should always chose the version with quiescent current, i.e. in case of power failure the door can be opened.



Components

Locking devices	TVR1 door locking unit electric strikes
Voltage	12 VDC / 24 VDC, for details please see the types
Principle of working	quiescent current (unlocked without current)
Feedback contact	with feedback contact
Accessories	separate feed-back contacts



TVR1 Door Lock

The TVR1 door lock features double safety against breaking open and manipulation. Amongst others it is verified whether the closed door is really locked in the lock.

When actuating the Emergency-Open switch, the electromagnet integrated in the TVR becomes currentless. The bolt enters reliably, even with a load up to 3000 N already pressing on the door. Against breaking open from the outside the holding force of the bolt is 6000 N. Each door can be equipped with two TVR1 door locks at a maximum.

Installation

Generally the TVR1 locking unit is vertically inserted in the lateral frame of the door, the bolt being up. It can also be installed in the frame above the door, with the bolt showing downwards. The door lock requires about 85 mm in depth. It must be made sure that the gap between locking unit and striking plate is no less than 3 mm and no more than 5 mm.

Dimensions

Important:

The TVR1 door lock should only be used on doors being sufficiently solid. Only then the bolt will always reliably enter the opening in the striking plate and unbolt again.

With light door constructions a winding or lowering door leaf may negatively influence the accurate functioning of the bolt.

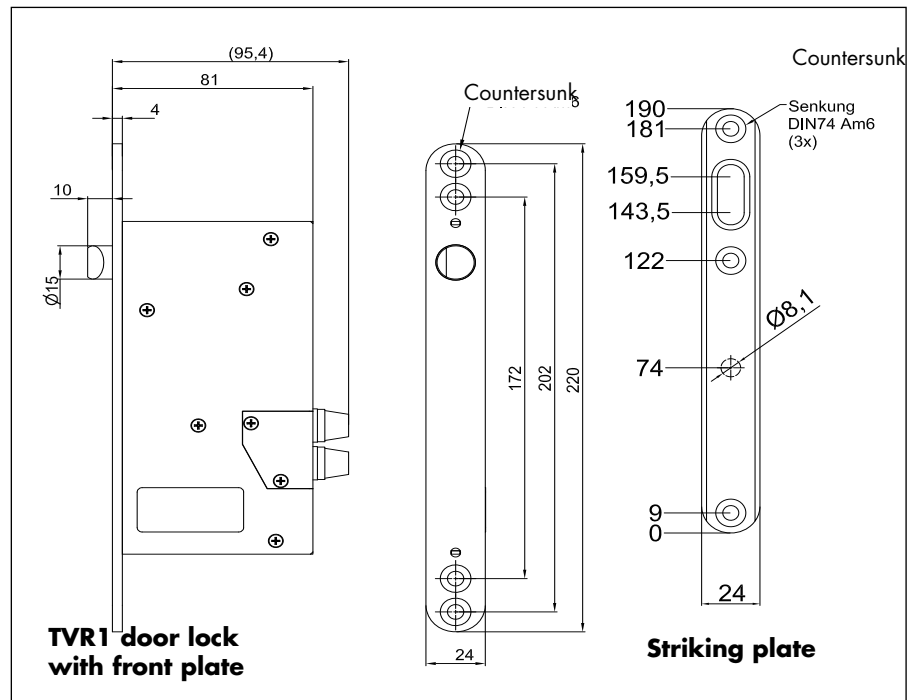

Technical Data

Voltage	24 VDC ± 10 %
Power consumption	max. 80 mA when locked
Locking force	6000 N (against breaking the door open)
Safe unlocking up to a load of	3000 N (in exit direction)
Duty cycle	100 %
Principle of working	quiescent current (unlocked without current)
IP rating	IP 30
Feedback contact	yes
Operating temperature	-10 °C to +40 °C

Order Information

TVR1 door lock, for doors DIN left	part no. 710750
TVR1 door lock, for doors DIN right	part no. 710751



Roureg 3 Electric Strike

Sometimes electric strikes are an alternative to bar magnets for locking doors. In combination with the DICTATOR interlock control system you have to use an electric strike being unlocked without current, i.e. the door can be opened in case of a power failure.

Due to its symmetrical design the Roureg 3 electric strike can be used on right- and left-handed doors. It only needs very little space as the door latch centres on its own axle. It is adjustable up to 3 mm.

The choice of the corresponding striking plate depends on the door, whether it is additionally equipped with a door lock or is to be kept locked only by the electric strike.

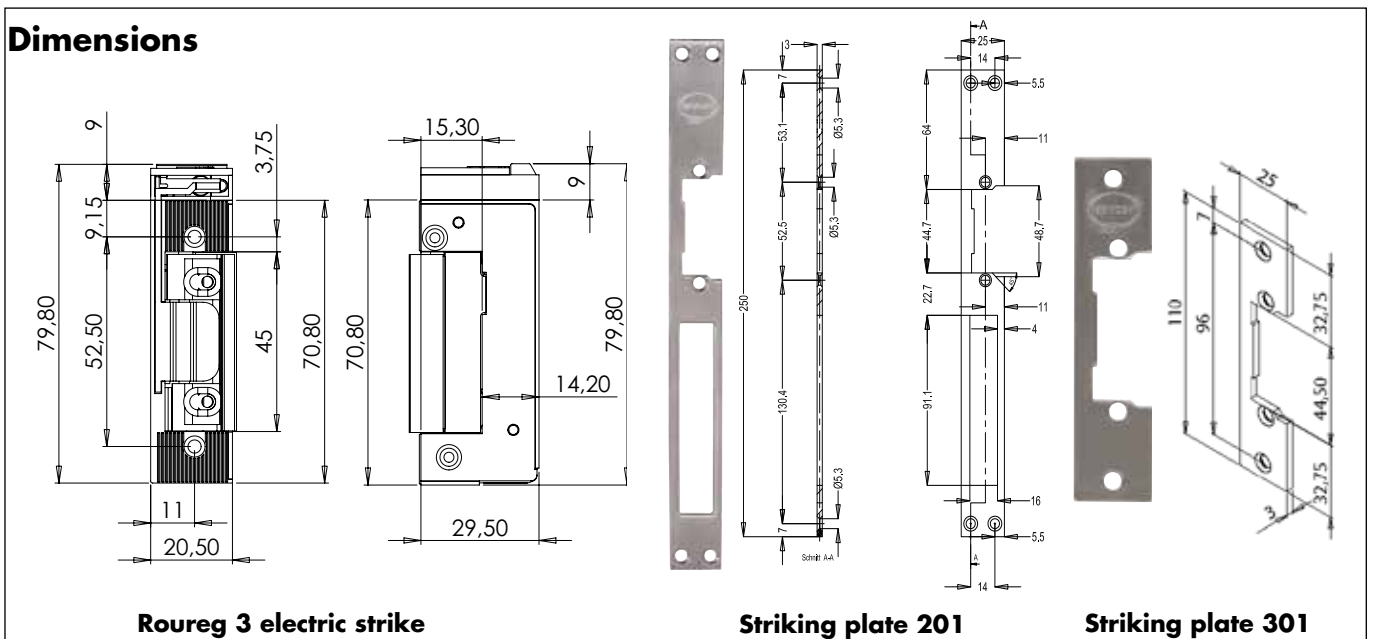

Technical Data

Voltage	24 VDC ± 10 %
Power consumption	120 mA
Locking force	5000 N (against breaking open the door)
Safe unlocking up to a load of	2000 N (in exit direction)
Duty cycle	100 %
Principle of working	quiescent current (unlocked without current)
Material	opener die casting, striking plate stainless steel
IP rating	IP 42
Feedback contact	yes
Protection device	integrated free-wheeling diode

Order Information

Roureg 3 electric strike, with free-wheeling diode + feed-back contact	part no. 041780
Long striking plate 201	part no. 041781
Short striking plate 301	part no. 041782



Electric Strike for Escape Routes

In combination with the emergency exit terminal of the DICTATOR interlock control system (see page 08.043.00) are certified, beside several bar magnets, also the following electric strikes for emergency exit doors.

Usually, due to its small dimensions, the electric strike 332.80-F91 will be used. The symmetric form allows to use it both on DIN right and DIN left doors. In addition it can also be installed horizontally. It is equipped with an adjustable FaFix safety catch (adjustment range 4 mm).

As a counter part for this electric strike you need one of the following striking plates. The choice of the corresponding striking plate depends on the type of door.

Dimensions

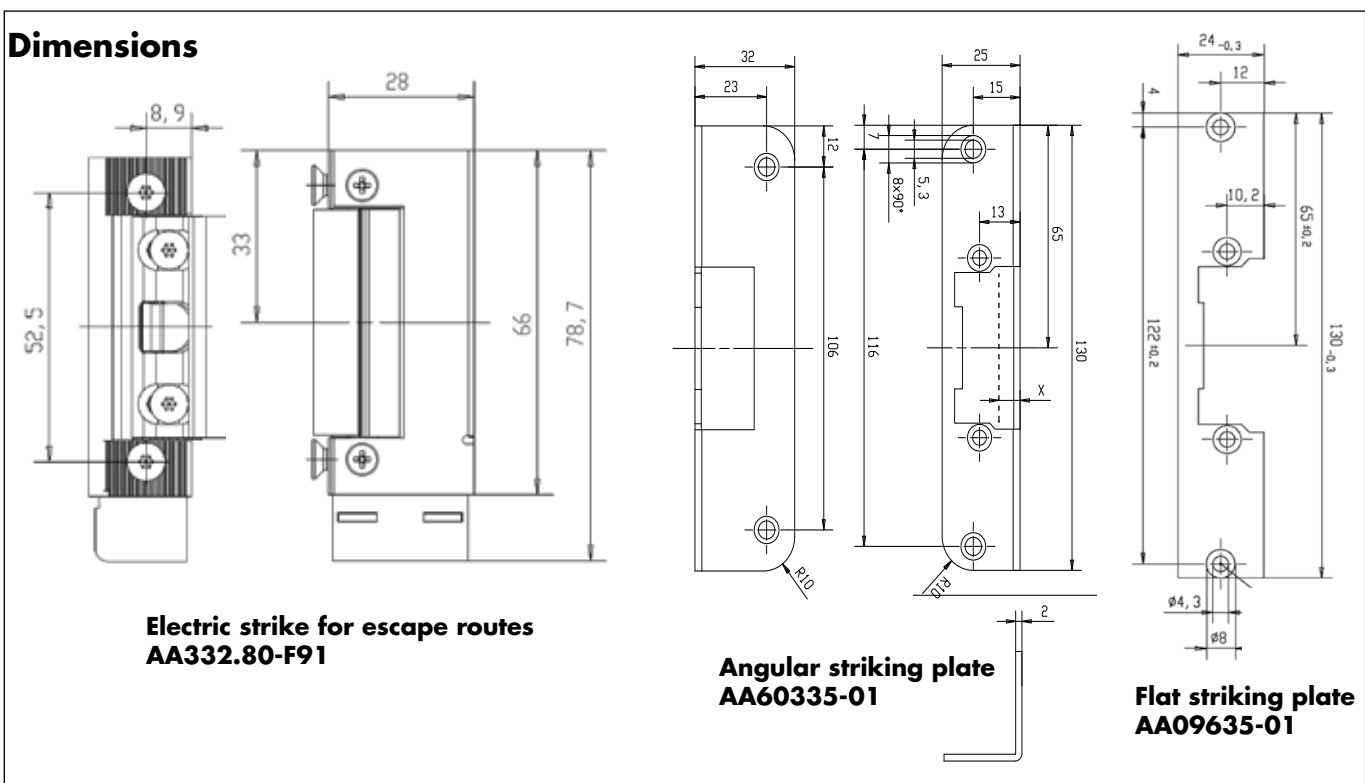

Technical Data

Voltage	24 VDC ± 10 %
Power consumption	100 mA
Locking force	3000 N (against breaking open the door)
Safe unlocking up to a load of	3000 N
Funktional principle	quiescent current (unlocked without current)
Operating temperature	-15 °C to +40 °C
Feedback contact	yes
Switching capacity	24 V/1 A
Material	steel
Protection	integrated diode

Order Information

Electric strike for escape routes 332.80-F91	part no. AA332.80-F91
Angular striking plate 60335-01 for above, stainless steel	part no. AA60335-01
Short, flat striking plate 09635-01 for above, stainless steel	part no. AA09635-01



Electric Strike for Fire Protection Doors in Escape Routes

In case the emergency exit door is also a fire protection door, this door has to be equipped with an especially certified electric strike for escape routes. The electric strike 331U80F-F94 or -F95 is approved as an additional locking device for fire protection doors. This electric strike is produced in two versions, one for doors DIN left and one for doors DIN right. The FaFix safety catch offers an adjusting range of 2 mm. The electric strike can be installed either vertically or horizontally.

As a counter part you need one of the striking plates shown below. The model depends on the type of the door.

The illustration shows the version for doors DIN left.

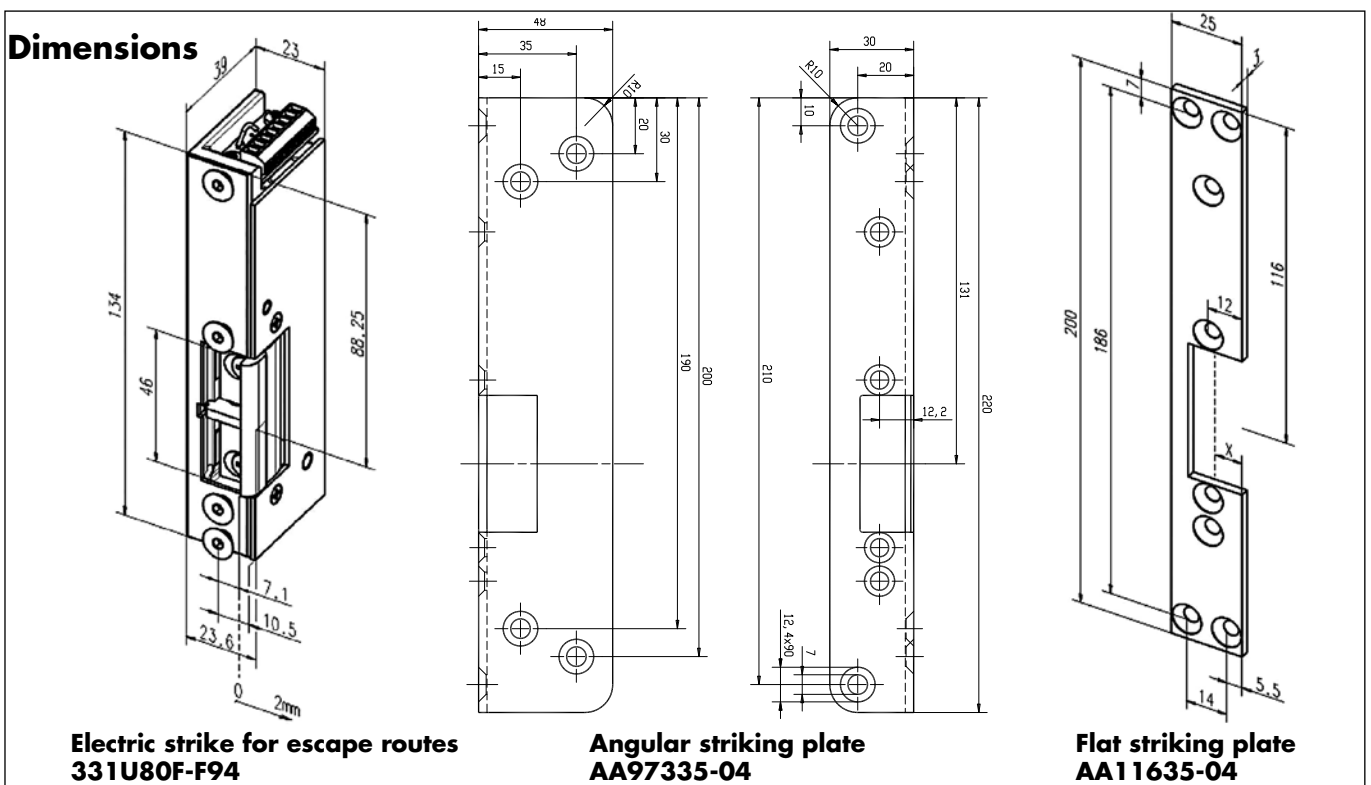

Technical Data

Voltage	24 VDC ± 10 %
Power consumption	100 mA
Locking force	5000 N (against breaking open the door)
Safe unlocking up to a load of	5000 N
Funktional principle	quiescent current (unlocked without current)
Operating temperature	-15 °C to +40 °C
Feedback contact	yes
Switching capacity	24 V/1 A
Material	steel
Protection	integrated diode

Order Information

	Part no. right	left
Electric strike for escape routes 331U80F, zinc-plated	AA331U80F-F95	AA33...-F94
Angular striking plate 97335, stainless steel	AA97335-05	AA97335-04
Flat striking plate 11635, stainless steel	AA11635-05	AA11635-04

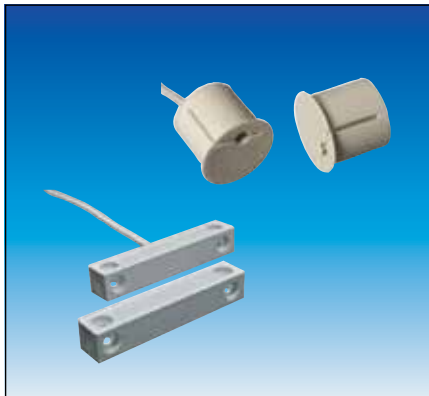

Accessories: Feedback Contact

In case a door system is equipped with bar magnets or electric door openers without feedback contact, you can retrofit separate feedback contacts.

The eccentric feedback contact for flush mounting, due to its eccentric design, offers easy adjusting to the installation situation and thus an always sure feedback. This is required when using it with bar magnets in the DICTATOR interlock control system.

These two feedback contacts are available either as make contact (NO) or as changeover. For the DICTATOR interlock control system a NO is needed.

Dimensions

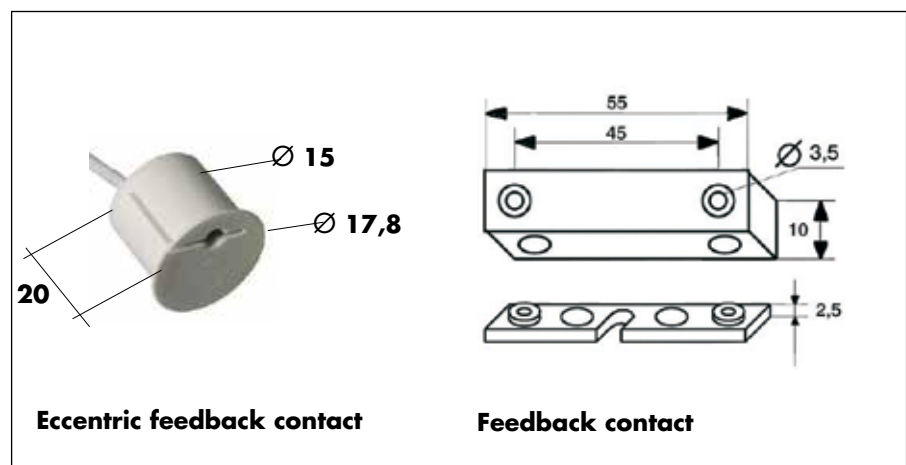

Technical Data

	Eccentric feedback contact	Feedback contact
Dimensions	17.8 x 15 x 20 mm	see dimensioned drawing
Max. switching capacity	30 V / 0.5 A	NO: 100 VDC/0.5 A changeover: 30 VDC/0.2 A
Material	ABS white	
Operating temperature	-20 °C to +70 °C	
IP rating	IP 68	IP 68
Activating distance	12 mm	NO: 30 mm changeover: 23 mm
Magnetic contact	NO (connection cable with 2 wires) or changeover (connection cable with 3 wires)	
Electric connection	connection cable of 4 m (eccentric feedback contact) connection cable of 2 m (feedback contact)	

Order Information

Eccentric feedback contact white, NO	part no. 040686
Eccentric feedback contact white, changeover	part no. 040685
Feedback contact, NO, incl. mounting accessories	part no. 040688
Feedback contact, changeover, incl. mounting accessories	part no. 040687

Access Control System

Interlock control systems often comprise rooms where only specially authorised people are admitted. These rooms require an access control system in addition to the DICTATOR interlock control system.

Access control can be effected either by a PIN or by a contactless card reader.

The system presented on the following page is a compact unit. It combines in one set the inserting/reading unit and the control unit. This is ideal for single door systems as it doesn't require much wiring.

The time span can be adjusted during which access is possible after having entered the pin/card. Another possibility is to open the door with the PIN/card and to lock it again with the next entry. Two relay outputs permit to pass on information.

The two multicoloured LEDs of the device optically signal the operation and the programming.



Product Range

Access control system KR1000

PIN, contactless with card
number of PINs: 1010



Access Control System KR1000

The access control system KR1000 comprises both entering and controlling device. This makes it ideal for single installations.

The access control is possible either by PIN or by card.

The access control system KR1000 is completely made from stainless steel. It can be operated with 12 or 24 VDC/AC. The keypad is always illuminated.

For the contactless access control per card we supply transponders in different colours: black, green, red and yellow.

Technical Data

Voltage	12 VDC/AC $\pm 10\%$	24 VDC/AC $\pm 10\%$
Power consumption	220 mA	110 mA
Power consumption non-operated	80 mA	40 mA
IP rating	IP 65	
Operating temperature	-20 °C to +50 °C	
Relay outputs	2 make/break contacts with switching capacity 2 A, 30 VDC or 0,5 A, 125 VAC	
Programmable time span	1 - 90 seconds	
Operation	PIN code and/or transponder transponder type 125 kHz, 64 Bit, EM 4100/4200 and EM 4102	
Number of PINs	1010	
Displays/alarm	2 LEDs (red-yellow-green or yellow-green), freely programmable, integrated buzzer	
Manipulation protection	unit blocks after 5 wrong entries for 30 s, buzzing	
Programming level	protected by master code or master card Programming is indicated by LED.	
Keypad	permanently illuminated, blue	
Dimensions (H x W x D)	120 x 76 x 28 mm	
Connection cable	3 m	
Casing	stainless steel	

Transponder



Order Information

Access control system KR1000, surface type	part no. 710880
Transponder black, EM 4102, 125 kHz, 64 Bit	part no. 710850
Transponder red, EM 4102, 125 kHz, 64 Bit	part no. 710851
Transponder yellow, EM 4102, 125 kHz, 64 Bit	part no. 710852
Transponder green, EM 4102, 125 kHz, 64 Bit	part no. 710853

Power Packs

The DICTATOR **interlock control system** requires a central power pack for the power supply of the interlock control terminals and the locking devices.

For this purpose and also other applications DICTATOR offers power packs with different output.

In addition to the power packs for changing 230 VAC in 24 VDC or 12 VDC, DICTATOR furnishes emergency power supplies: for the 230 VAC supply or on demand also as a power pack with integrated batteries to back up the 24 VDC supply.

The required type and capacity depend on the connected consumers. The 24 VDC power packs with 2.7 A and 5 A have especially been designed for the newest generation of the DICTATOR interlock control system. They are completely provided with pluggable connection cables, i.e. the 230 VAC power cable is just plugged in a normal socket and the cable for the power supply of the distribution box(es) is plugged in the corresponding plug-in position.

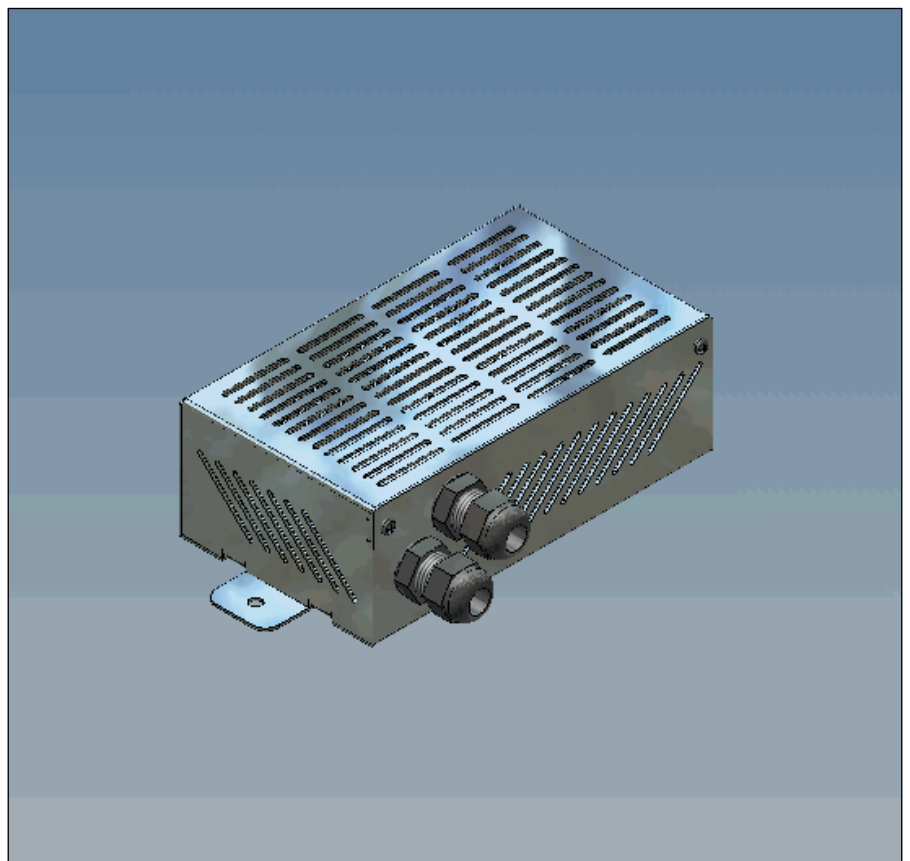

Technical Data

Power packs	24 VDC:	1.1 A, 2.7 A, 5 A
	12 VDC:	5 A
UPS power supplies	230 VAC:	800 VA / 500 W
	24 VDC:	on demand
	12 VDC:	on demand

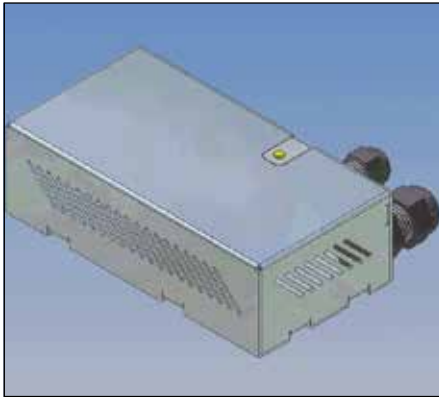

24 VDC, 1.1 A Power Pack

The 24 VDC, 1.1 A power pack is designed for the **use in small interlock systems**. It features a power cable and also a connection cable to the distribution box or the central control of the newest generation of the DICTATOR interlock control system.

A green luminous diode on the casing indicates the proper functioning of this power pack.

Dimensions

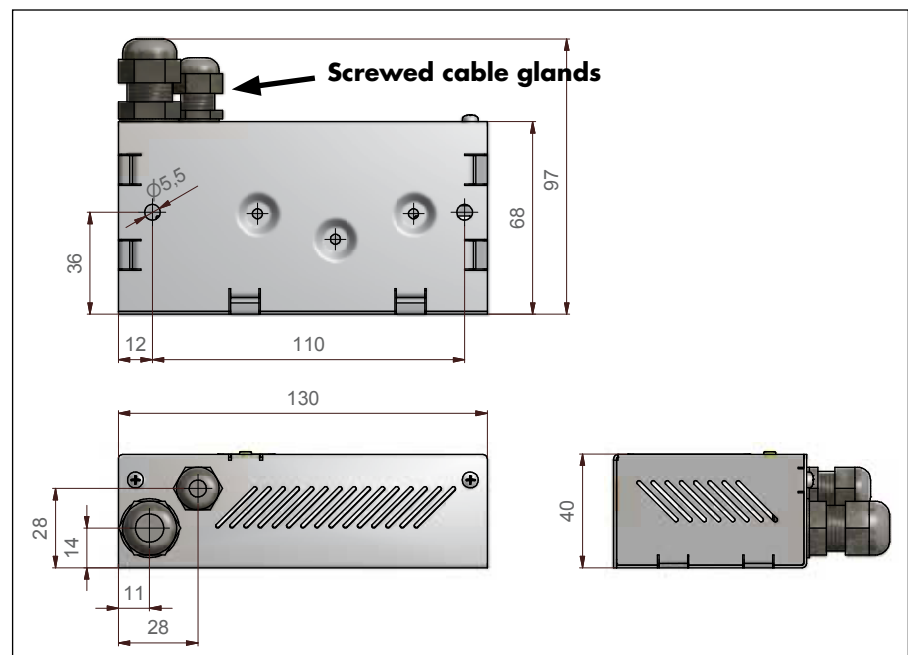

Installation

The 1.1 A power pack may be installed only in dry rooms. When the surrounding temperature drops below 0 °C, make sure that no ice can form in the power pack.

During service the power pack heats up. Therefore take care that air can circulate through the lateral ventilation slots.

The casing is fixed via two holes \varnothing 5.5 mm in the bottom of the casing. For the connection to the mains and the connected devices two screwed cable glands M12 and M16 are provided.

Technical Data

Voltage	100 - 240 VAC / 46 - 63 Hz
Power consumption max.	0.8 A
Output voltage	24 VDC (+/-10 %)
Output current (depending on type)	1.1 A
Operating temperature	-10 °C to +50 °C
IP rating (according to DIN 40050)	IP 30 / Only for dry surroundings!
Casing	AISI 304 stainless steel
Mains connection	1.5 m mains cable with safety plug
24 V connection to the distribution box	2.0 m cable with 6 pin plug

Order Information

24 VDC 1.1 A power pack	part no. 710780-1
-------------------------	-------------------

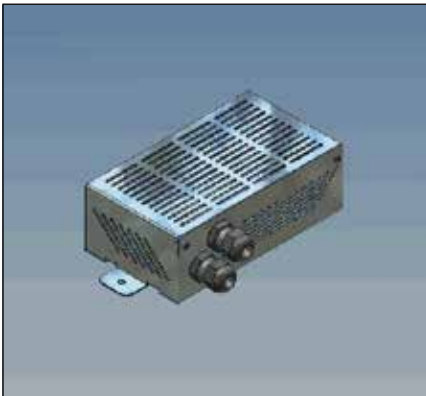

24 VDC, 2.7 A or 5 A Power Packs

The 2.7 A and 5 A NT3 power packs have **especially** been designed for the **newest generation of the interlock control system**. Both power packs are furnished in the same casing, their outer dimensions being the same.

Usually the 2.7 A power pack should be sufficient. (Please check the consumption of the single components.)

Dimensions

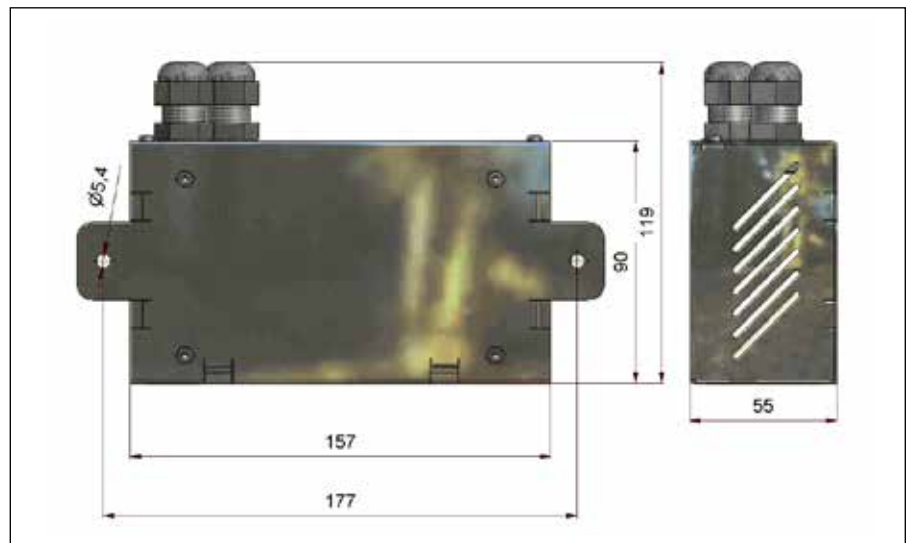

Installation/Connection

The 2.7 A and 5 A power packs may be installed in dry rooms only. When the surrounding temperature drops below 0 °C, it has to be made sure that no ice forms in the power packs.

During service the power packs heat up. Therefore make sure that the lateral ventilation slots are free and the air can circulate.

The new design of the NT3 power packs makes it superfluous to open them. For the connection to the 230 VAC power supply there is a 1.5 m power cable with safety plug. To one of the distribution boxes VK3 or a central controller it is connected by a 2 m long cable provided with a 6-pin connector. This connector is plugged-in in the distribution box/central controller. There is no more connection work required.

For the fixing 2 lateral brackets are provided.

Technical Data

Voltage	100 - 240 VAC / 46 - 63 Hz
Power consumption (depending on type)	max. 0.9 A / 1 A
Output voltage	24 VDC (+/-10 %)
Output current (depending on type)	2.7 A (65 W) / 5 A (120 W)
Operating temperature	-10 °C to +50 °C
Protection (according to DIN 40050)	IP 30 / Only for dry surroundings!
Casing	AISI 304 stainless steel
Mains connection	1.5 m power cable with safety plug
24 V connection to distribution box	2 m cable with 6-pin connector

Order information

NT3 power pack, 24 VDC 2.7 A	part no. 710782
NT3 power pack, 24 VDC 5 A	part no. 710783

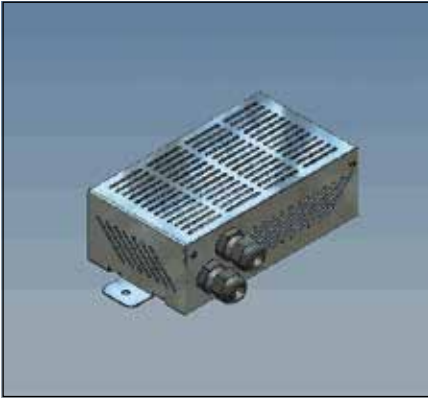

12 VDC, 5 A Power Pack

Especially the separate power supply of the access controls in interlock control systems requires a 12 VDC power supply.

Dimensions

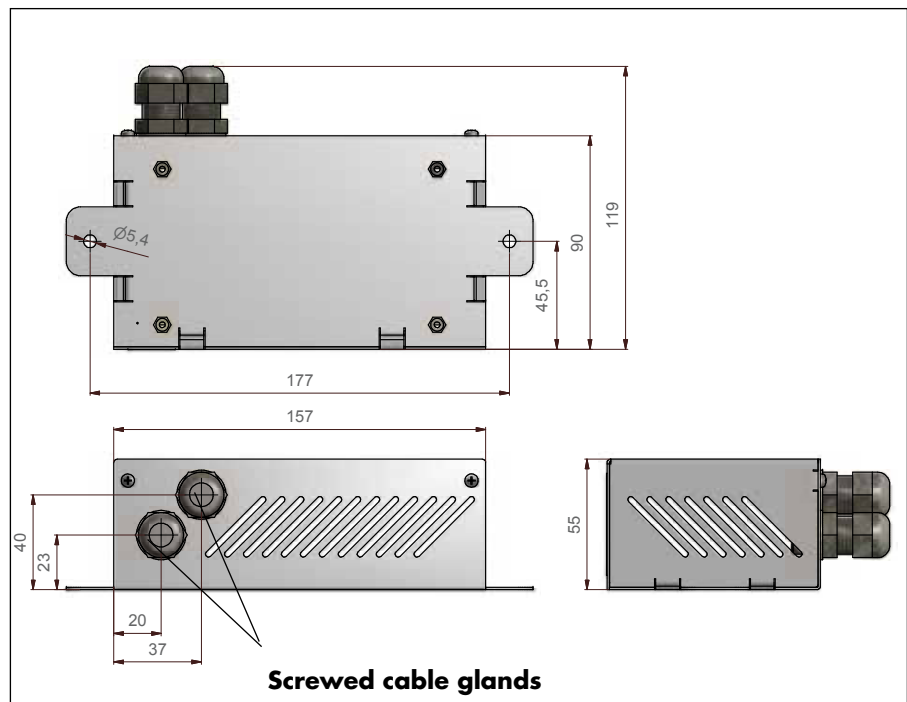

Installation

The power packs may only be installed in dry rooms. When the surrounding temperature drops below 0 °C, it has to be made sure that no ice can form in the power packs. During service the power packs heat up. Therefore make sure that air can circulate through the lateral ventilation slots.

The casing is fixed via two holes \varnothing 5.5 mm in its bottom. For the connection to the mains and the connected devices two screwed cable glands M12 and M16 are provided.

Technical Data

Voltage	100 - 240 VAC / 46 - 63 Hz
Power consumption	max. 0.72 A
Output voltage	12 VDC (+/-10 %)
Output current	5 A
Operating temperature	-10 °C to +50 °C
IP rating (according to DIN 40050)	IP 30 / Only for dry surroundings!
Casing	AISI 304 stainless steel

Order Information

12 VDC, 5 A power pack

part no. 710781



UPS Power Supply ellipse 800

In general doors in emergency exits are safely locked, but in an emergency it must be easy to open them. That means that in case of a power failure the emergency door is not locked any more, as only this represents the "safe" state and permits an unhindered escape.

To keep these doors locked also in case of a power cut, you can connect the complete interlock control system to an **extern 230 VAC UPS power supply**. The power supply ellipse 800 provides at a load of 50 % (i.e. connected consumers with about 250 W) for about 11 minutes the power supply. UPS systems for longer periods are available on demand.

Configuration

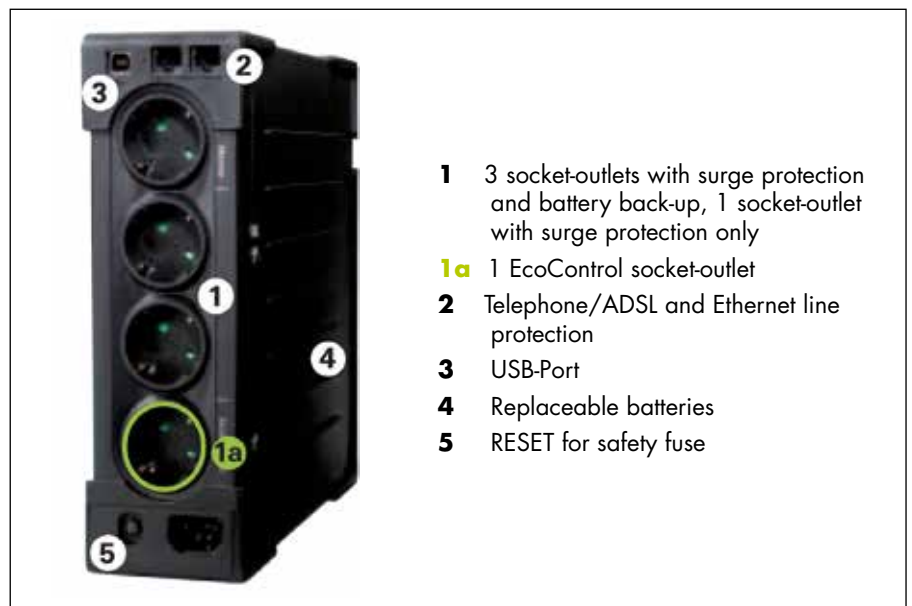

The UPS power supply ellipse 800 is designed for the use in dry surroundings only. The battery needs no maintenance. It is charged automatically and its state of charge is supervised. It is protected against total discharge. If it needs to be replaced, this will be indicated (LED + acoustic alarm).

Technical Data

Capacity	800 VA / 500 W
Input voltage	184 - 264 VAC
Output voltage	230 VAC (adjustable to 220/230/240 V)
Frequency	50 - 60 Hz (automatic recognition)
Power failure bridging time	about 11 minutes at 50 % load
Socket-outlets	see above
Input protection	resettable safety fuses
Protection against total discharge	4 hours
Dimensions (w x h x d)	81 x 263 x 235 mm
Battery	maintenance-free lead-acid battery
Conformity to standards	IEC/EN 62040-1-1, IEC/EN 60950 IEC 62040-2, IEC 61643-1, CB-Report

Order Information

UPS power supply ellipse 800 part no. 710785

